

Scheda Tecnica / Technical Details / Fiche Technique	
Cod. Art. VI 235 T	
IT ::	Valvola a farfalla Wafer
EN ::	Wafer butterfly valve
FR ::	Vanne papillon à plaquettes

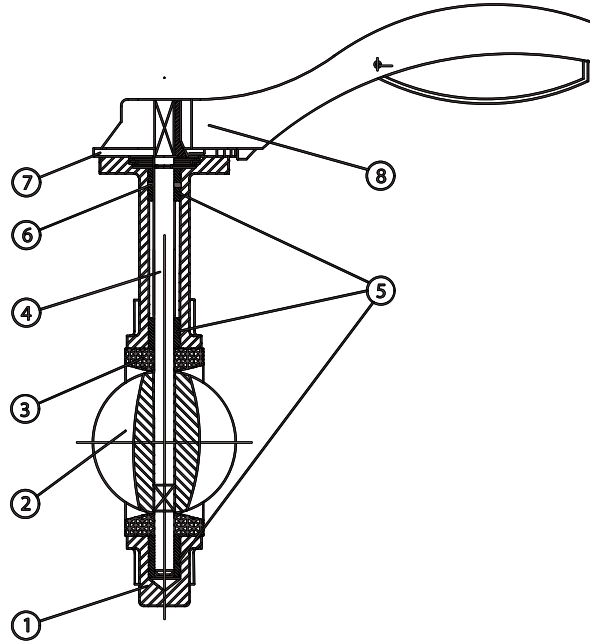

DESCRIZIONE DEI COMPONENTI

	Descrizione	Materiale
1	Corpo	Ghisa Sferoidale - GGG 40 (EN-GJS-400-15)
2	Disco	Ghisa Sferoidale Nichelata - GGG40 (EN-GJS-400-15)
3	Guarnizione	EPDM
4	Stelo	Acciaio Inox AISI 416
5	Boccole	PTFE
6	Tenuta	EPDM
7	Piastra Indicatore	Acciaio al Carbonio
8	Leva	Alluminio

CARATTERISTICHE TECNICHE

- Pressione di lavoro: PN 16.
- Temperatura di lavoro: da -10 °C a 120 °C.
- Adattabile a flange: PN 10 / 16.
- Rivestimento esterno "EPOXY", 250 µm.
- Flangia per il montaggio di attuatori ISO 5211.
- Distanza tra le flange: UNI EN 558 Serie 20.
- Valvola di regolazione.
- Stelo in un unico pezzo.
- Non sono necessarie guarnizioni per il montaggio tra le flange
- Possibilità di bloccare la valvola con un lucchetto.
- Collo lungo per facilitare l'isolamento termico della valvola
- Design bidirezionale.

APPLICAZIONI GENERALI

- Sistemi idraulici.
- Sistemi e approvvigionamento idrico e di pompaggio.
- Applicazioni industriali a pressioni e temperature moderate.
- Sistemi di irrigazione.
- Opere idrauliche e civili.
- Climatizzazione.

Osservazioni:

Data la complessità, la varietà e l'elevato numero di specifiche particolari di ciascuna installazione, unitamente all'esistenza di vari fattori che possono influenzare le condizioni di lavoro e la natura del prodotto, è responsabilità dell'utente finale eseguire le prove necessarie per garantire il corretto funzionamento del prodotto in ogni specifica applicazione.

L'installazione del prodotto deve essere eseguita e mantenuta secondo codici di buona pratica e/o norme vigenti.

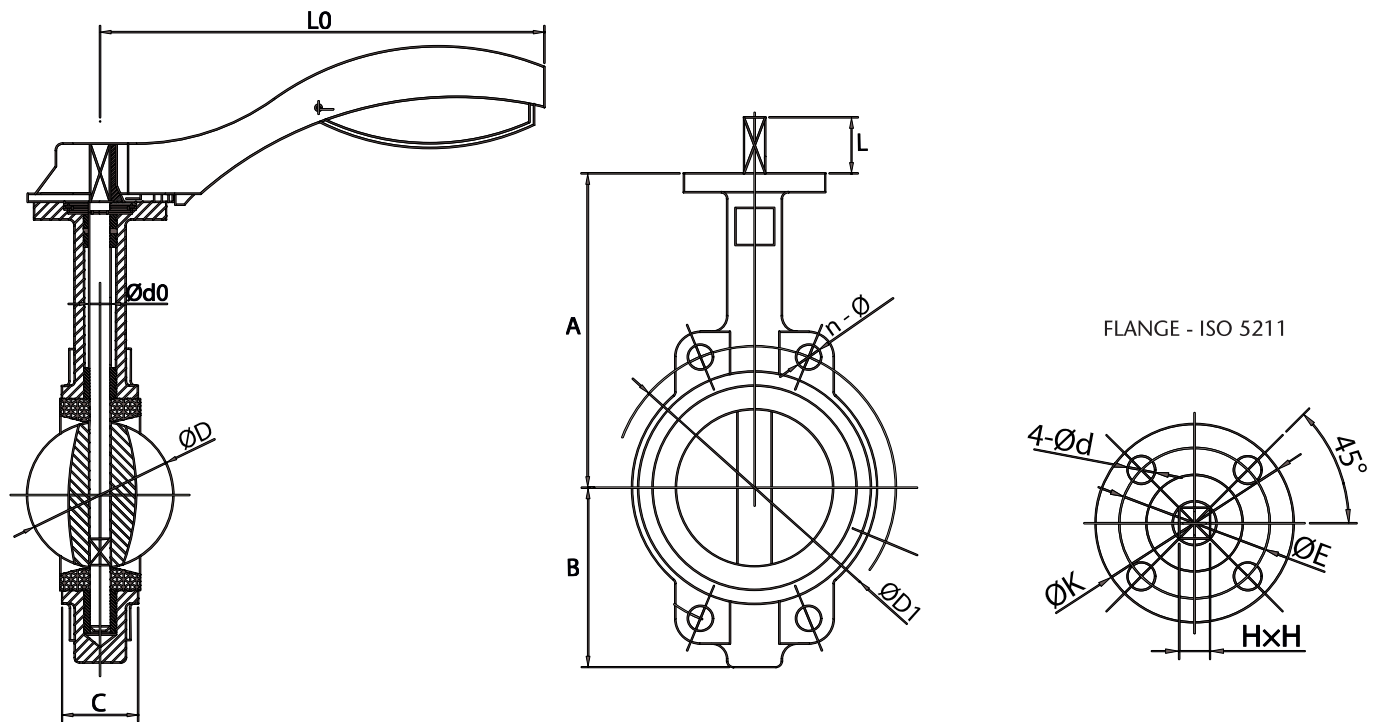

INFORMAZIONI TECNICHE

DN	COD.	DIMENSIONI										FLANGE - ISO 5211			Peso appros.	
		A	B	C	Ød0	ØD	ØD1	n - Ø	L	L0	H x H	4 - Ød	K	E		
40	VI0235T04000	134	66	33	11,0	42,8	110	4 - 19	24	170	9 x 9	F05	4 - 7	70	50	2,50
50	VI0235T05000	161	75	43	12,6	52,9	125	4 - 19	29	170	9 x 9	F05	4 - 7	70	50	2,58
65	VI0235T06500	175	89	46	12,6	64,5	145	4 - 19	29	170	9 x 9	F05	4 - 7	70	50	3,17
80	VI0235T08000	181	95	46	12,6	78,8	160	8 - 19	26	170	11 x 11	F05	4 - 7	70	50	3,54
100	VI0235T10000	200	114	52	15,8	104,0	180	4 - 19	26	170	11 x 11	F05	4 - 7	70	50	4,72
125	VI0235T12500	215	127	56	18,9	123,3	210	4 - 19	28	220	14 x 14	F07	4 - 9	90	70	6,45
150	VI0235T15000	230	139	56	18,9	155,1	240	4 - 23	32	220	14 x 14	F07	4 - 9	90	70	7,74
200	VI0235T20000	260	175	60	22,1	202,5	295	4 - 23	29	260	17 x 17	F07	4 - 9	90	70	11,7
250	VI0235T25000	292	203	68	28,5	250,5	355	4 - 28	38	350	22 x 22	F10	4 - 12	125	102	20,0
300	VI0235T30000	337	242	78	31,6	301,6	410	4 - 28	34	350	22 x 22	F10	4 - 12	125	102	29,0

Nota: a causa del costante sviluppo dei nostri prodotti, i dati presenti in questa scheda tecnica possono variare senza preavviso



ISTRUZIONI PER L'INSTALLAZIONE

Vedere il disegno A:

- Confermare il corretto allineamento tra le flange;
- Lasciare uno spazio sufficiente tra le flange per inserire la valvola senza danneggiare l'elastomero;
- Il disco deve trovarsi nella posizione indicata nel disegno, **MAI IN POSIZIONE DI CHIUSURA**.

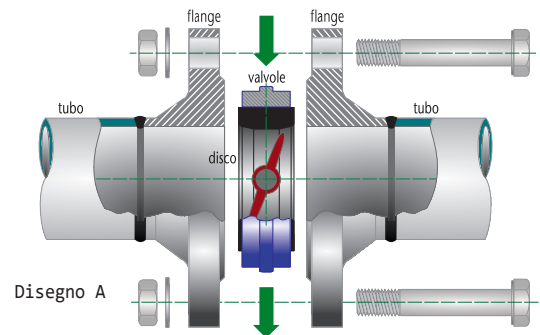

Vedere il disegno B:

- Non inserire guarnizioni tra le flange e la valvola.

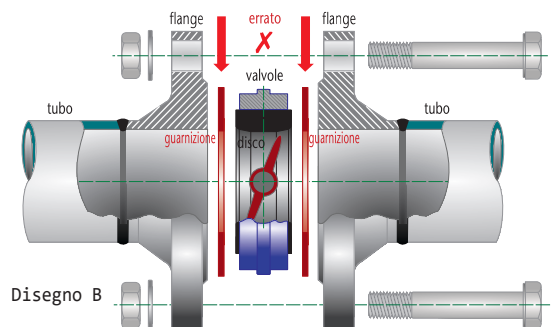

Vedere il disegno C:

- Le flange devono essere adatte, assicurarsi che non ostriscano l'apertura del disco;
- Fissare i bulloni delle flange senza serrare i dadi e **APRIRE COMPLETAMENTE LA VALVOLA**;
- Serrare i bulloni in modo simmetrico e uniforme fino a raggiungere il contatto metallo-metallo tra le flange e la valvola.

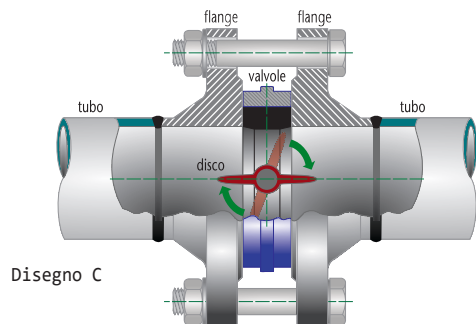

Vedere il disegno D:

- Utilizzare flangia a collarino o, in assenza, flangia piana con il tubo saldato all'estremità delle flange.

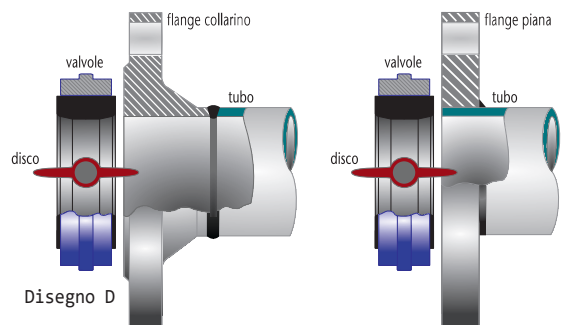

Considerazioni importanti:

- Non saldare mai le flange alle tubazioni con la valvola già assemblata;
- Non montare sulla valvola altri elementi a contatto elastico, ad esempio un giunto di espansione; Il contatto deve sempre essere metallo (valvola) contro metallo (flangia);
- Per le valvole fino a DN 300 con liquidi puliti, lo stelo può essere collocato in posizione verticale o orizzontale. Per diametri superiori è obbligatorio il montaggio con lo stelo in posizione orizzontale;
- Il sistema di ancoraggio/supporto deve essere adatto alle forze del sistema.

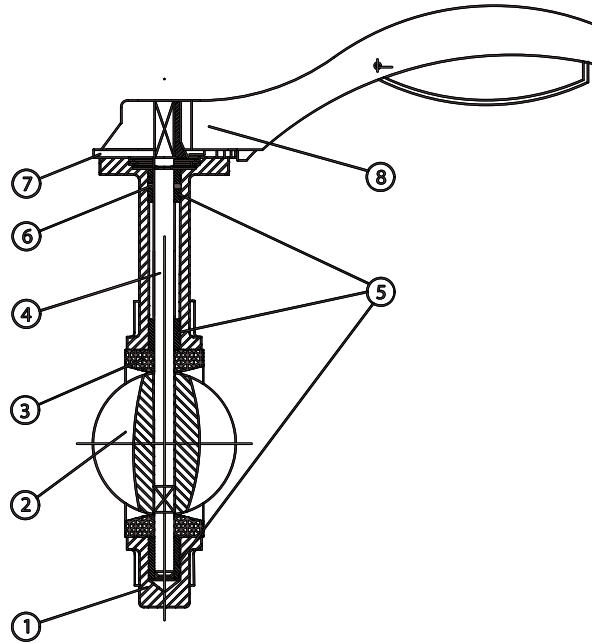

DESCRIPTION OF COMPONENTS

	Description	Material
1	Body	Ductile iron - GGG 40 (EN-GJS-400-15)
2	Disc	Nickel-Plated Ductile Iron - GGG 40 (EN-GJS-400-15)
3	Gasket	EPDM
4	Stem	Stainless Steel AISI 416
5	Bushings	PTFE
6	Seat	EPDM
7	Indicator plate	Carbon Steel
8	Lever	Aluminium

TECHNICAL CHARACTERISTICS

- Working pressure: PN 16;
- Working temperature: -10°C to +120°C;
- Adaptable to flanges PN 10 / PN 16;
- External coating "EPOXY", 250 µm;
- Flange for mounting ISO 5211 actuators;
- Distance between flanges: UNI EN 558 Series 20;
- Control valve;
- One-piece stem;
- No gaskets are required for mounting the flanges;
- Possibility of locking the valve with a padlock;
- Long neck to facilitate thermal insulation of the valve;
- Two-way design.

GENERAL APPLICATIONS

- Hydraulic systems;
- Water supply and pumping systems;
- Industrial applications at moderate pressures and temperatures;
- Irrigation systems;
- Hydraulic and civil works;
- Air conditioning.

Observations:

Given the complexity, variety, and numerous specific requirements of each installation, along with the various factors that may influence the operating conditions and the nature of the product, it is the end user's responsibility to perform the necessary tests to ensure proper operation of the product in each specific application. Product installation must be performed and maintained in accordance with applicable codes of practice and/or standards.

Note: Due to the constant development of our products, the data in this data sheet may change without notice.

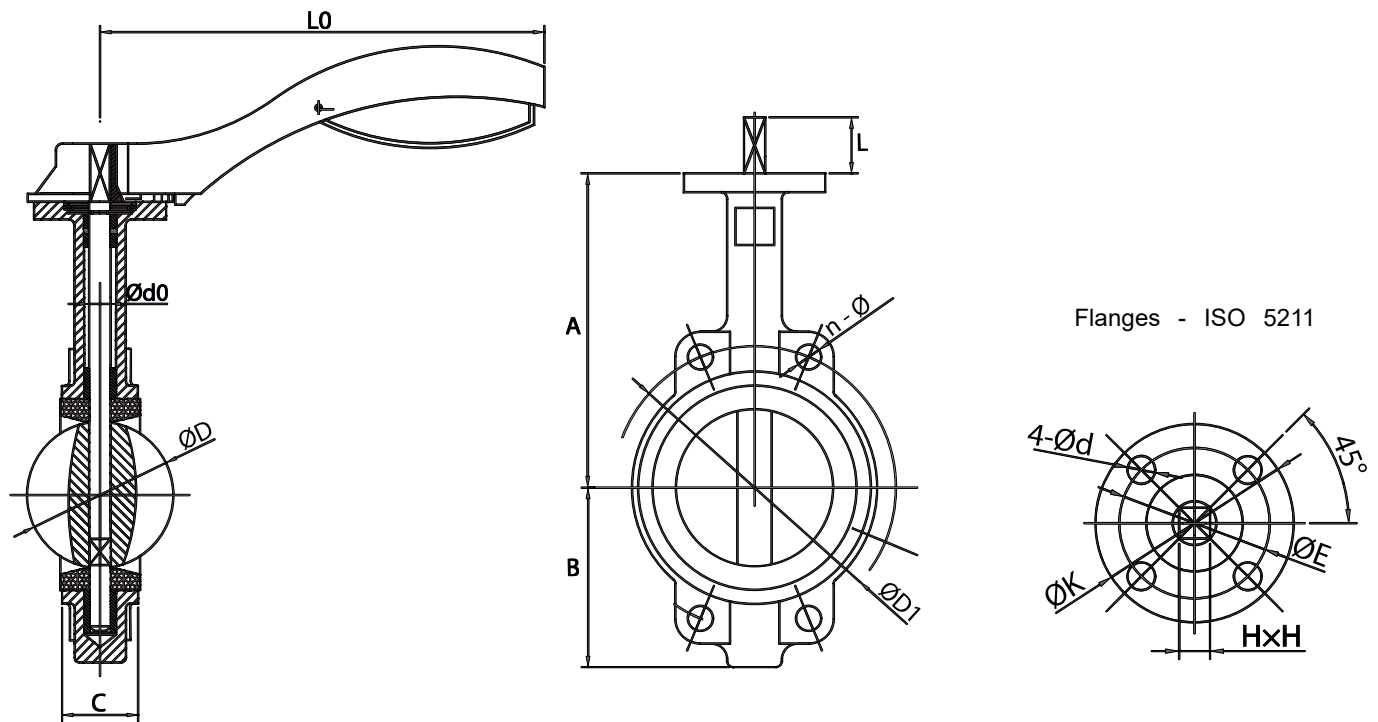

TECHNICAL INFORMATION

DN	COD.	DIMENSIONS										Flanges - ISO 5211			Weight	
		A	B	C	Ød0	ØD	ØD1	n - Ø	L	L0	H x H	4 - Ød	K	E		
40	VI0235T04000	134	66	33	11,0	42,8	110	4 - 19	24	170	9 x 9	F05	4 - 7	70	50	2,50
50	VI0235T05000	161	75	43	12,6	52,9	125	4 - 19	29	170	9 x 9	F05	4 - 7	70	50	2,58
65	VI0235T06500	175	89	46	12,6	64,5	145	4 - 19	29	170	9 x 9	F05	4 - 7	70	50	3,17
80	VI0235T08000	181	95	46	12,6	78,8	160	8 - 19	26	170	11 x 11	F05	4 - 7	70	50	3,54
100	VI0235T10000	200	114	52	15,8	104,0	180	4 - 19	26	170	11 x 11	F05	4 - 7	70	50	4,72
125	VI0235T12500	215	127	56	18,9	123,3	210	4 - 19	28	220	14 x 14	F07	4 - 9	90	70	6,45
150	VI0235T15000	230	139	56	18,9	155,1	240	4 - 23	32	220	14 x 14	F07	4 - 9	90	70	7,74
200	VI0235T20000	260	175	60	22,1	202,5	295	4 - 23	29	260	17 x 17	F07	4 - 9	90	70	11,7
250	VI0235T25000	292	203	68	28,5	250,5	355	4 - 28	38	350	22 x 22	F10	4 - 12	125	102	20,0
300	VI0235T30000	337	242	78	31,6	301,6	410	4 - 28	34	350	22 x 22	F10	4 - 12	125	102	29,0

Note: Due to the constant development of our products, the data in this data sheet may change without notice.



INSTALLATION INSTRUCTIONS

See drawing A:

- Confirm correct alignment between flanges;
- Leave enough space between the flanges to insert the valve without damaging the elastomer;
- The disc must be in the position shown in the drawing, NEVER IN THE CLOSED POSITION.

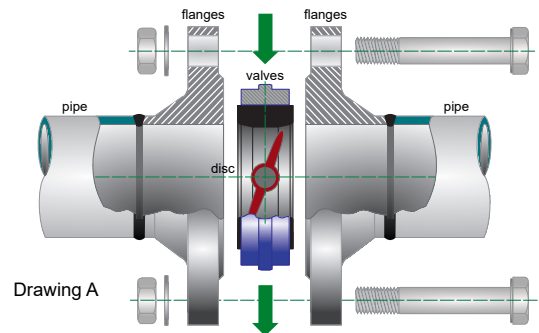

See drawing B:

- Do not insert gaskets between the flanges and the valve.

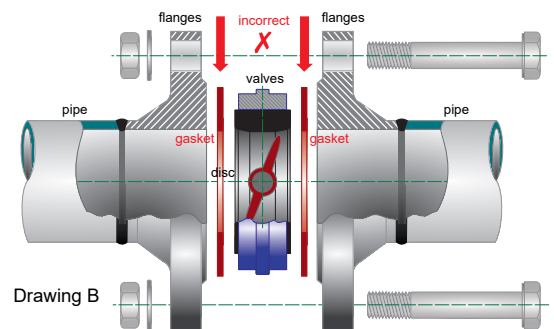

See drawing C:

- Flanges must fit, make sure they do not obstruct the disc opening;
- Secure the flange bolts without tightening the nuts and OPEN THE VALVE COMPLETELY;
- Tighten the bolts symmetrically and evenly until metal-to-metal contact is achieved between the flanges and the valve.

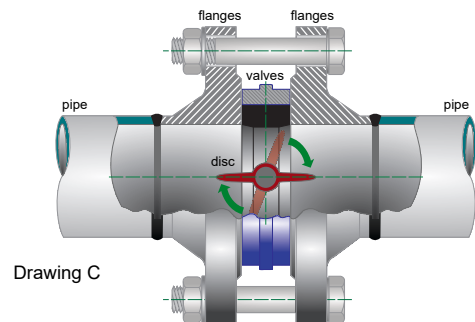

See drawing D:

- Use a collar flange or, if not available, a flat flange with the pipe welded to the ends of the flanges.

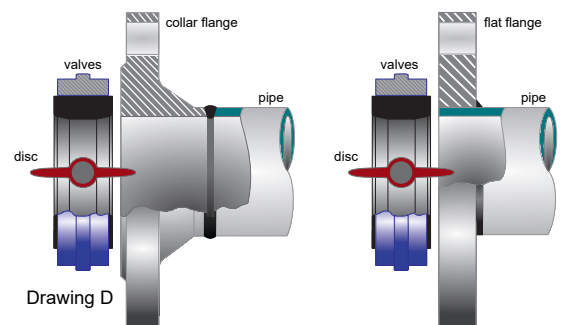

Important considerations:

- Never weld flanges to pipes with the valve already assembled;
- Do not install other elastic contact elements, such as an expansion joint, on the valve. Contact must always be metal (valve) to metal (flange);
- For valves up to DN 300 with clean liquids, the stem can be positioned vertically or horizontally; for larger diameters, horizontal stem installation is mandatory;
- The anchoring/support system must be suitable for the system forces.

Note: Due to the constant development of our products, the data in this data sheet may change without notice.

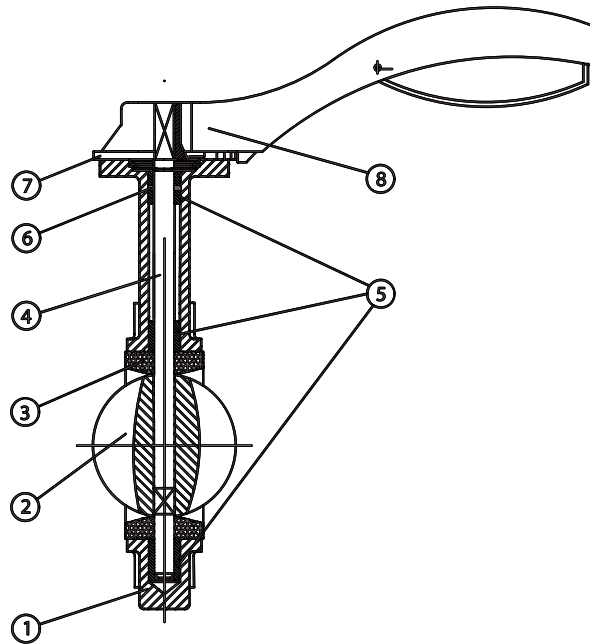

DESCRIPTION OF COMPONENTS

	Description	Matériel
1	Corps	Fonte ductile - GGG 40 (EN-GJS-400-15)
2	Disque	Fonte ductile nickelée - GGG 40 (EN-GJS-400-15)
3	Joint	EPDM
4	Tige	Acier inoxydable AISI 416
5	Bagues	PTFE
6	Siège	EPDM
7	Plaque indicatrice	Acier au carbone
8	Levier	Aluminium

CARACTÉRISTIQUES TECHNIQUES

- Pression de service : PN 16;
- Température de fonctionnement : -10°C à +120°C;
- Adaptable aux brides PN 10 / PN 16;
- Revêtement extérieur "EPOXY", 250 µm.
- Brides pour montage d'actionneurs ISO 5211;
- Distance entre les brides : UNI EN 558 Série 20;
- Vanne de régulation;
- Tige monobloc;
- Aucun joint n'est nécessaire pour le montage des brides;
- Possibilité de verrouiller la vanne avec un cadenas;
- Col long pour faciliter l'isolation thermique de la valve;
- Conception bidirectionnelle.

APPLICATIONS GÉNÉRALES

- Systèmes hydrauliques;
- Systèmes d'approvisionnement en eau et de pompage;
- Applications industrielles à pressions et températures modérées;
- Systèmes d'irrigation;
- Travaux hydrauliques et civils;
- Climatisation.

Observations :

Compte tenu de la complexité, de la diversité et des nombreuses exigences spécifiques de chaque installation, ainsi que des différents facteurs susceptibles d'influencer les conditions de fonctionnement et la nature du produit, il incombe à l'utilisateur final d'effectuer les tests nécessaires pour garantir le bon fonctionnement du produit dans chaque application spécifique.

L'installation et la maintenance du produit doivent être effectuées conformément aux codes de pratique et/ou aux normes en vigueur.

Remarque : En raison du développement constant de nos produits, les données de cette fiche technique peuvent changer sans préavis.

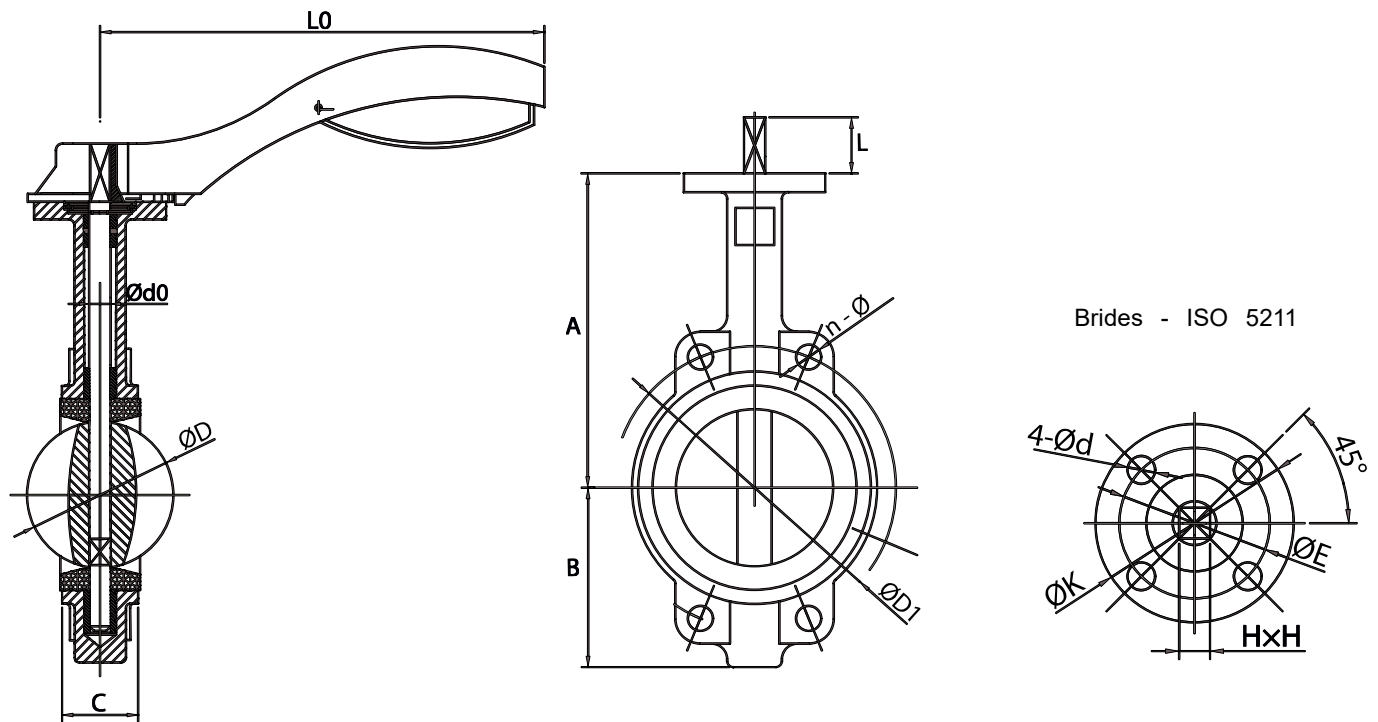

INFORMATIONS TECHNIQUES

DN	COD.	DIMENSIONS										Brides - ISO 5211			Poids	
		A	B	C	Ød0	ØD	ØD1	n - Ø	L	L0	H x H	4 - Ød	K	E		
40	VI0235T04000	134	66	33	11,0	42,8	110	4 - 19	24	170	9 x 9	F05	4 - 7	70	50	2,50
50	VI0235T05000	161	75	43	12,6	52,9	125	4 - 19	29	170	9 x 9	F05	4 - 7	70	50	2,58
65	VI0235T06500	175	89	46	12,6	64,5	145	4 - 19	29	170	9 x 9	F05	4 - 7	70	50	3,17
80	VI0235T08000	181	95	46	12,6	78,8	160	8 - 19	26	170	11 x 11	F05	4 - 7	70	50	3,54
100	VI0235T10000	200	114	52	15,8	104,0	180	4 - 19	26	170	11 x 11	F05	4 - 7	70	50	4,72
125	VI0235T12500	215	127	56	18,9	123,3	210	4 - 19	28	220	14 x 14	F07	4 - 9	90	70	6,45
150	VI0235T15000	230	139	56	18,9	155,1	240	4 - 23	32	220	14 x 14	F07	4 - 9	90	70	7,74
200	VI0235T20000	260	175	60	22,1	202,5	295	4 - 23	29	260	17 x 17	F07	4 - 9	90	70	11,7
250	VI0235T25000	292	203	68	28,5	250,5	355	4 - 28	38	350	22 x 22	F10	4 - 12	125	102	20,0
300	VI0235T30000	337	242	78	31,6	301,6	410	4 - 28	34	350	22 x 22	F10	4 - 12	125	102	29,0

Remarque : En raison du développement constant de nos produits, les données de cette fiche technique peuvent changer sans préavis.



INSTALLATION INSTRUCTIONS

Voir dessin A:

- Confirmer l'alignement correct entre les brides;
- Laisser suffisamment d'espace entre les brides pour insérer la valve sans endommager l'élastomère;
- Le disque doit être dans la position indiquée sur le dessin, JAMAIS EN POSITION FERMÉE.

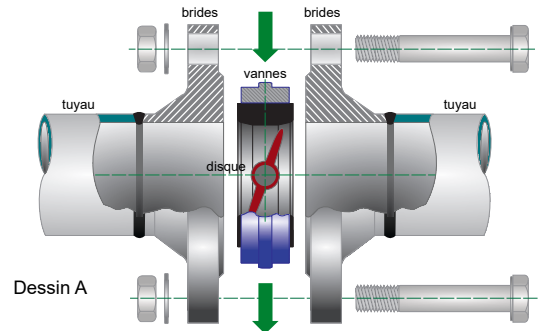

Dessin A

Voir dessin B:

- Ne pas insérer de joints entre les brides et la vanne.

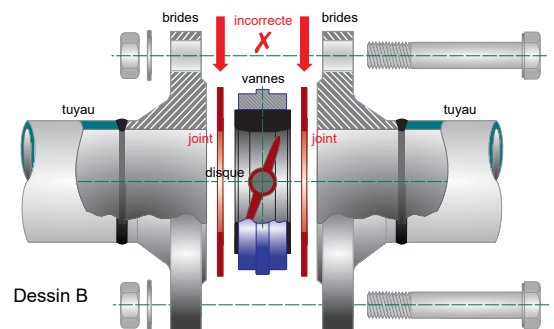

Dessin B

Voir dessin C:

- Les brides doivent s'adapter, veillez à ce qu'elles n'obstruent pas l'ouverture du disque;
- Serrez les boulons de la bride sans serrer les écrous et OUVREZ COMPLÈTEMENT LA VANNE;
- Serrez les boulons de manière symétrique et uniforme jusqu'à obtenir un contact métal sur métal entre les brides et la vanne.

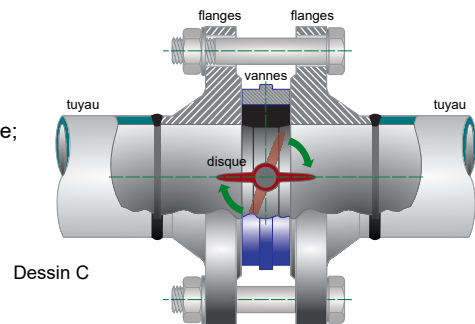

Dessin C

Voir dessin D:

- Utiliser une bride à collerette ou, à défaut, une bride plate avec le tuyau soudé aux extrémités des brides.

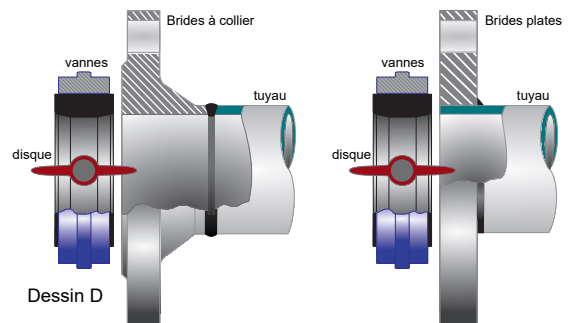

Dessin D

Considérations importantes :

- Ne jamais souder des brides sur des tuyaux avec la vanne déjà assemblée;
- Ne pas installer d'autres éléments de contact élastiques, tels qu'un compensateur de dilatation, sur la vanne. Le contact doit toujours être métal (vanne) contre métal (bride);
- Pour les vannes jusqu'à DN 300 avec liquides propres, la tige peut être positionnée verticalement ou horizontalement; pour les diamètres supérieurs, l'installation de la tige horizontale est obligatoire;
- Le système d'ancrage/support doit être adapté aux forces du système.

Remarque : En raison du développement constant de nos produits, les données de cette fiche technique peuvent changer sans préavis.