



🇮🇹 Normativa ed identificazione

- Norma di Produzione e di uso EN 10242: 1994.
- Identificazione: In accordo con il materiale scelto per la produzione ed il tipo di filetto, i raccordi EO sono identificati di classe "A", ciò significa che sono prodotti generalmente in fusione malleabile a cuore bianco di alta qualità EN-GJMW 400 - 5. Inoltre sono filettati secondo le ISO 7/1 con filetto interno cilindrico (Rp) e filetto esterno conico (R).

🇬🇧 Normativa ed identificazione

- Production and use standard EN 10242: 1994.
- Identification: In accordance with the material chosen for production and the type of thread, EO fittings are identified as class "A", which means that they are generally produced in high quality white heart malleable casting EN-GJMW 400 - 5 They are also threaded according to ISO 7/1 with cylindrical internal thread (Rp) and conical external thread (R).

🇫🇷 Normativa ed identificazione

- Norme de fabrication et d'utilisation EN 10242 : 1994.
- Identification : Conformément au matériau choisi pour la production et au type de filetage, les raccords EO sont identifiés comme appartenant à la classe "A", ce qui signifie qu'ils sont généralement produits en fonte malléable à cœur blanc de haute qualité EN-GJMW 400 - 5 Ils sont également fileté selon ISO 7/1 avec filetage intérieur cylindrique (Rp) et filetage extérieur conique (R).

Diametro nominale e misura di connessione / Nominal diameter and connection size / Diamètre nominal et taille de raccordement

DN	6	8	10	15	20	25	32	40	50	65	80	100	125	150
G	1/8"	1/4"	3/8"	1/2"	3/4"	1"	1 1/4"	1 1/2"	2"	2 1/2"	3"	4"	5"	6"

Relazione pressione-temperatura / pressure-temperature relationship / Relation pression-température

Temperature di esercizio (°C)	Pressione di lavoro massima (bar)
-20 fino 120	25
Tra 120 e 300	valori interpolati
300	20

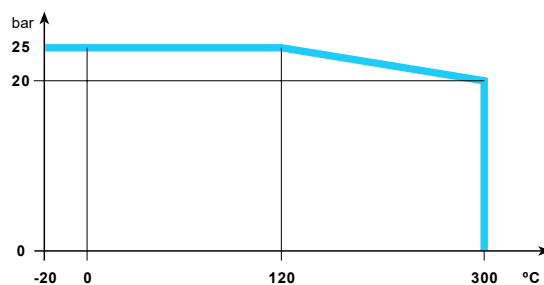

Per utilizzi in condizioni differenti da quelle indicate, chiedere informazioni al nostro ufficio tecnico

RA 01 Curva ampia 90° M-F
 Large elbow 90° M-F
 Coude large 90° M-F

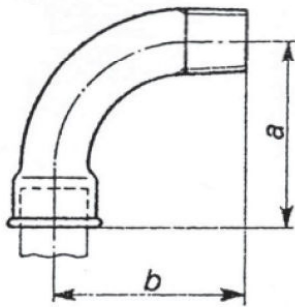

Diametri Ø	Dimensioni / Dimensions mm	
	a	b
3/8	48	42
1/2	55	48
3/4	69	60
1	85	75
1.1/4	105	95
1.1/2	116	105
2	140	130
2.1/2	176	165
3	205	190
4	260	245
5	305	288
6	351	333

RA 02 Curva ampia 90° F-F
 Large elbow 90° F-F
 Coude large 90° F-F

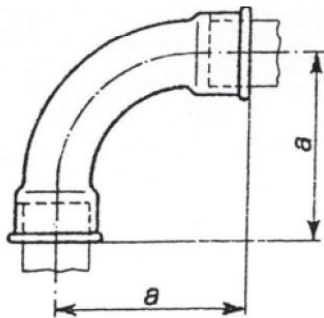

Ø	Dimensioni / Dimensions mm
	a
3/8	48
1/2	55
3/4	69
1	85
1.1/4	105
1.1/2	116
2	140
2.1/2	176
3	205
4	260

RA 40 Curva ampia 45° M-F
 Large elbow 45° M-F
 Coude large 45° M-F

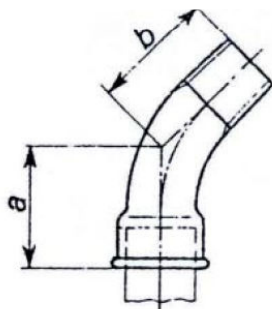

Ø	Dimensioni / Dimensions mm	
	a	b
1/2	36	30
3/4	43	36
1	51	42
1.1/4	64	54
1.1/2	68	58
2	81	70
(2.1/2)	99	86
(3)	113	100
4	142	125

RA 41 Curva ampia 45° F-F
Large elbow 45° F-F
Coude large 45° F-F

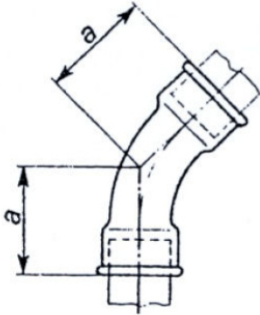

Ø	Dimensioni / Dimensions mm
	a
1/2	36
3/4	43
1	51
1.1/4	64
1.1/2	68
2	81
(2.1/2)	99
(3)	113
4	142

RA 85 Scavalca tubo F-F
Override pipe F-F
Dérogation tuyau F-F

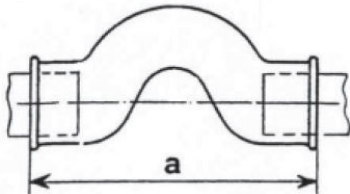

Ø	Ø Tubo da sorpassare Ø Pipe to overtake Ø Pipe à dépasser	a mm
1/2	1/2	90
3/4	3/4	106
1	1	140

RA 90 Gomito 90° F-F
Elbow 90° F-F
Coude 90° F-F

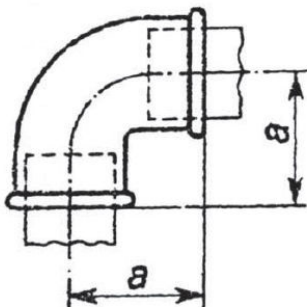

Ø	Dimensioni / Dimensions mm
	a
1/8	19
1/4	21
3/8	25
1/2	28
3/4	33
1	38
1.1/4	45
1.1/2	50
2	58
2.1/2	69
3	78
4	96
5	115
6	131

RA 92 Gomito 90° M-F
Elbow 90° M-F
Coude 90° M-F

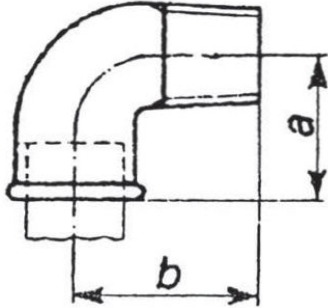

Ø	Dimensioni / Dimensions mm	
	a	b
1/8	19	25
1/4	21	28
3/8	25	32
1/2	28	37
3/4	33	43
1	38	52
1.1/4	45	60
1.1/2	50	65
2	58	74
2.1/2	69	88
3	78	98
4	96	118

RA 96 Bocchettone 90° F-F
Bent union 90° F-F
raccord 3 pièces 90° F-F

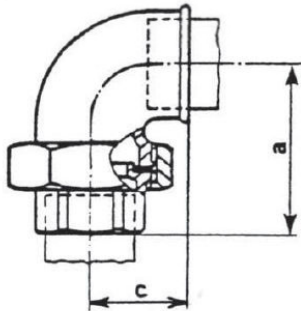

Ø	a mm	c mm
3/8	52	25
1/2	58	28
3/4	62	33
1	72	38
1.1/4	82	45
1.1/2	90	50
2	100	58
2.1/2	122	70
3	135	78

RA 529 Prolungamento M-F
Bent union 90° M-F
Socked extension M-F

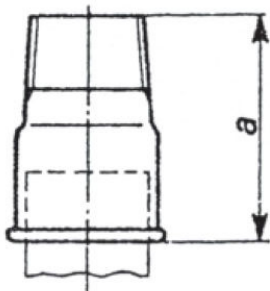

Diametri Ø	Dimensioni / Dimensions mm
	a
3/8	35
1/2	43
3/4	48
1	55
1.1/4	60
1.1/2	63
2	70

RA 98 Bocchettone 90° M-F
Bent union 90° M-F
raccord 3 pièces 90° M-F

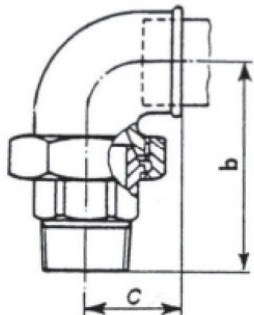

Ø	b mm	c mm
3/8	65	25
1/2	76	28
3/4	82	33
1	94	38
1.1/4	107	45
1.1/2	115	50
2	128	58
2.1/2	152	70
3	168	78

RA 120 Gomito 45° F-F
Elbow 45° F-F
Coude 45° F-F

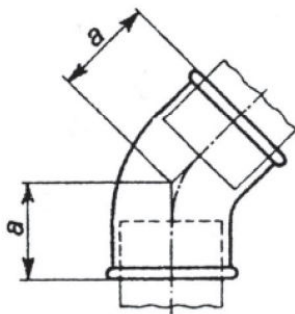

Ø	Dimensioni / Dimensions mm	
	a	
1/2	22	
3/4	25	
1	28	
1.1/4	33	
1.1/2	36	
2	43	

RA 121 Gomito 45° M-F
Elbow 45° M-F
Coude 90° M-F

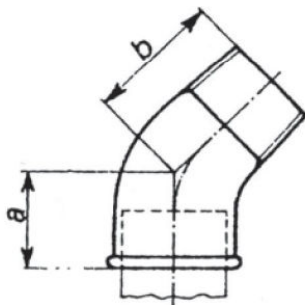

Ø	Dimensioni / Dimensions mm	
	a	b
1/2	22	28
3/4	25	32
1	28	37
1.1/4	33	43
1.1/2	36	46
2	43	55

RA 241 Riduzione M-F
Reduction M-F
Réduction M-F

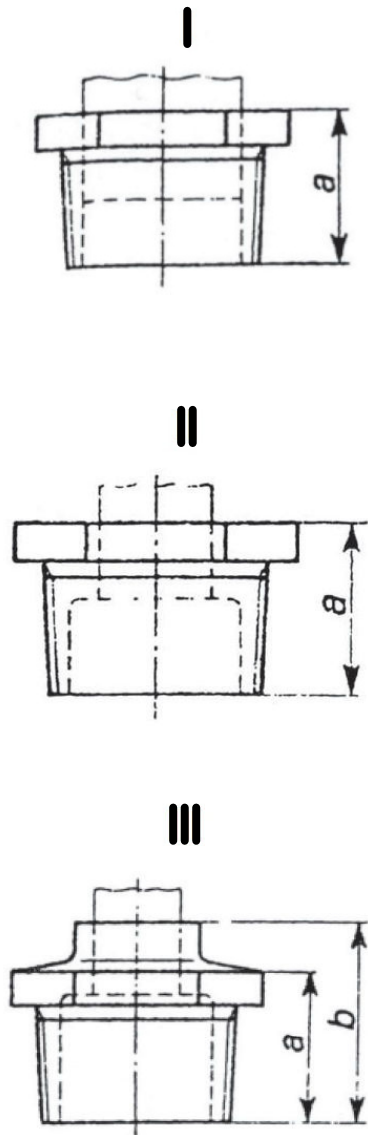

Ø	Modello	Dimensioni / Dimensions mm	
		a	b
1/2 x 1/4	II	24	-
1/2 x 3/8	-	22	-
3/4 x 3/8	II	26	-
3/4 x 1/2	I	26	-
1 x 3/8	II	29	-
1 x 1/2	II	29	-
1 x 3/4	I	29	-
1.1/4 x 3/8	II	31	-
1.1/4 x 1/2	II	31	-
1.1/4 x 3/4	II	31	-
1.1/4 x 1	I	31	-
1.1/2 x 3/8	II	31	-
1.1/2 x 1/2	II	31	-
1.1/2 x 3/4	II	31	-
1.1/2 x 1	II	31	-
1.1/2 x 1.1/4	I	31	-
2 x 1/2	III	35	48
2 x 3/4	III	35	48
2 x 1	II	35	-
2 x 1.1/4	II	35	-
2 x 1.1/2	II	35	-
2.1/2 x 1	III	40	54
2.1/2 x 1.1/4	III	40	54
2.1/2 x 1.1/2	II	40	-
2.1/2 x 2	II	40	-
3 x 1	III	44	59
3 x 1.1/4	III	44	59
3 x 1.1/2	III	44	59
3 x 2	II	44	-
3 x 2.1/2	II	44	-
4 x 1	-	54	-
4 x 1.1/4	-	56	-
4 x 1.1/2	-	55	-
4 x 2	III	51	69
4 x 2.1/2	III	51	69
4 x 3	II	51	-
5 x 3	-	58	-
5 x 4	II	61	-
6 x 3	-	65	-
6 x 4	III	65	87
6 x 5	-	66	-

RA 130 T 90° F-F

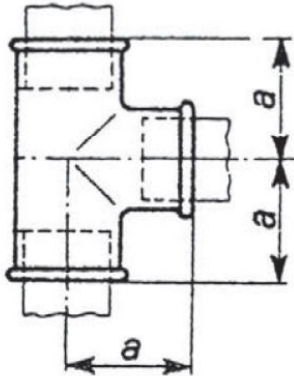

Ø	Dimensioni / Dimensions mm	
	a	
1/8	19	
1/4	21	
3/8	25	
1/2	28	
3/4	33	
1	38	
1.1/4	45	
1.1/2	50	
2	58	
2.1/2	69	
3	78	
4	96	
5	115	
6	131	

RA 131 T ridotto F-F-F
Reducing T F-F-F
Réduire T F-F-F

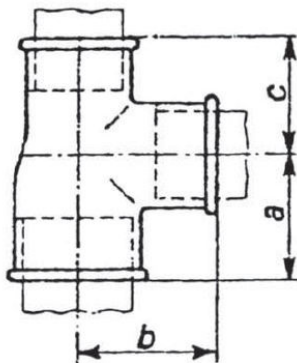

Ø	Dimensioni / Dimensions mm		
	a	b	c
1/2 x 1/2 x 3/8	30	30	27
3/4 x 1/2 x 1/2	33	35	30
3/4 x 3/4 x 3/8	36	36	30
3/4 x 3/4 x 1/2	36	36	32
1 x 1/2 x 1/2	35	36	30
1 x 1/2 x 3/4	35	36	33
1 x 3/4 x 1/2	38	39	33
1 x 3/4 x 3/4	38	39	35
1 x 1 x 1/2	40	40	39
1 x 1 x 3/4	40	40	39
1.1/4 x 1/2 x 1	37	41	37
1.1/4 x 3/4 x 3/4	39	44	36
1.1/4 x 3/4 x 1	39	44	38
1.1/4 x 1 x 1	43	45	40
1.1/4 x 1.1/4 x 1/2	48	48	40
1.1/4 x 1.1/4 x 3/4	48	48	44
1.1/4 x 1.1/4 x 1	48	48	45
1.1/2 x 1/2 x 1.1/4	38	43	37
1.1/2 x 3/4 x 1.1/4	40	47	39
1.1/2 x 1 x 1	45	49	41
1.1/2 x 1 x 1.1/4	45	49	43
1.1/2 x 1.1/4 x 1.1/4	49	50	48
1.1/2 x 1.1/2 x 1/2	53	53	45
1.1/2 x 1.1/2 x 3/4	53	53	47
1.1/2 x 1.1/2 x 1	53	53	49
1.1/2 x 1.1/2 x 1.1/4	53	53	51
2 x 3/4 x 1.1/2	43	53	45
2 x 1.1/4 x 1.1/4	50	-	48
2 x 1.1/2 x 1.1/2	55	58	54
2 x 2 x 1	61	61	55
2 x 2 x 1.1/4	61	61	57
2 x 2 x 1.1/2	61	61	58
2.1/2 x 2 x 2	65	71	65
2.1/2 x 2.1/2 x 2	72	72	69

RA 131 Tee ridotto F-F-F
Reduced tee F-F-F
Té réduit F-F-F

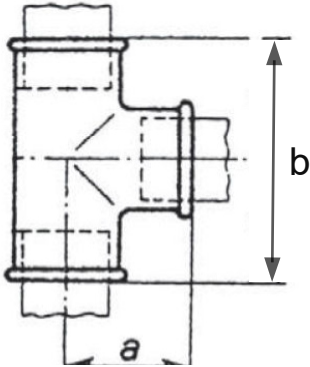

Ø	Dimensioni / Dimensions mm	
	a	b
2.1/2 x 3/4 x 2.1/2	47	62
2.1/2 x 1 x 2.1/2	49	63
2.1/2 x 1.1/4 x 2.1/2	55	65
2.1/2 x 1.1/2 x 2.1/2	58	66
2.1/2 x 2 x 2.1/2	64	69
3 x 1 x 3	54	70
3 x 1.1/4 x 3	56	72
3 x 1.1/2 x 3	60	73
3 x 2 x 3	66	76
3 x 2.1/2 x 3	74	79
4 x 1.1/2 x 4	66	86
4 x 2 x 4	73	89
4 x 2.1/2 x 4	80	92
4 x 3 x 4	88	96

RA 91 Gomito ridotto F-F
Reducing elbow F-F
Coude réducteur F-F

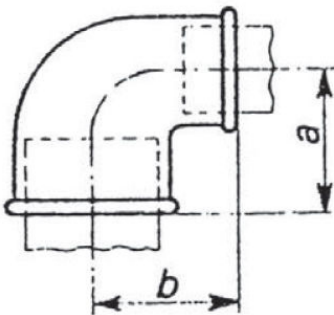

Ø	Dimensioni / Dimensions mm	
	a	b
1/2 x 3/8	26	26
3/4 x 3/8	28	28
3/4 x 1/2	30	31
1 x 1/2	32	34
1 x 3/4	35	36
1.1/4 x 1/2	35	36
1.1/4 x 3/4	36	41
1.1/4 x 1	40	42
1.1/2 x 1/2	37	43
1.1/2 x 3/4	38	44
1.1/2 x 1	42	46
1.1/2 x 1.1/4	46	48
2 x 1	44	52
2 x 1.1/4	50	55
2 x 1.1/2	52	55
2.1/2 x 2	61	66
3 x 2	62	72
3 x 2.1/2	72	75

RA 270 Manicotto F-F
Coupling F-F
Manchon F-F

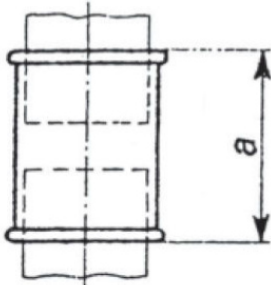

Ø	Dimensioni / Dimensions mm
	a
1/8	25
1/4	27
3/8	30
1/2	36
3/4	39
1	45
1.1/4	50
1.1/2	55
2	65
2.1/2	74
3	80
4	94
5	109
6	120

RA 240 Manicotto ridotto F-F
Reduced coupling F-F
Manche réduite F-F

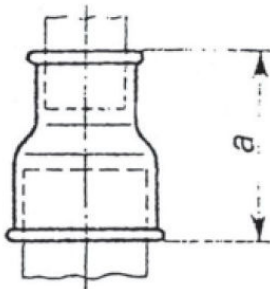

Ø	Dimensioni / Dimensions mm
	a
1/2 x 3/8	34 - 36
3/4 x 3/8	38 - 39
3/4 x 1/2	38 - 39
1 x 3/8	42 - 42
1x 1/2	42 - 45
1 x 3/4	42 - 43 - 45
1.1/4 x 1/2	48 - 50
1.1/4 x 3/4	48 - 50
1.1/4 x 1	48 - 49 - 50
1.1/2 x 1/2	52 - 55
1.1/2 x 3/4	52 - 55
1.1/2 x 1	52 - 55
1.1/2 x 1.1/4	52 - 59 - 55
2 x 1/2	58 - 65
2 x 3/4	58 - 65
2 x 1	58 - 65
2 x 1.1/4	58 - 65
2 x 1.1/2	58 - 65
2.1/2 x 1	65 - 71 - 74
2.1/2 x 1.1/4	65 - 74
2.1/2 x 1.1/2	65 - 74
2.1/2 x 2	65 - 74
3 x 1	72 - 80
3 x 1.1/4	72 - 80
3 x 1.1/2	72 - 80
3 x 2	72 - 80
3 x 2.1/2	72 - 80
4 x 2	85 - 94
4 x 2.1/2	85 - 94
4 x 3	85 - 94

RA 245 Nipplo ridotto M-M
Reducing nipple M-M
Mamelon réduit M-M

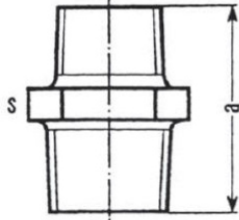

Ø	a mm	S chiave / Key mm
1/2 x 3/8	38	22
3/4 x 3/8	47	30
3/4 x 1/2	47	30
1 x 1/2	53	36
1 x 3/4	53	36
1.1/4 x 1/2	57	46
1.1/4 x 3/4	57	46
1.1/4 x 1	57	46
1.1/2 x 1/2	57	50
1.1/2 x 3/4	57	50
1.1/2 x 1	57	50
1.1/2 x 1.1/4	59	50
2 x 1	66	64
2 x 1.1/4	68	65
2 x 1.1/2	68	65
2.1/2 x 1.1/2	75	80
2.1/2 x 2	75	80
3 x 2	83	95
3 x 2.1/2	83	95
4 x 2	84	123
4 x 3	90	124

RA 246 Manicotto ridotto F-M
Reduced coupling F-M
Manche réduite F-M

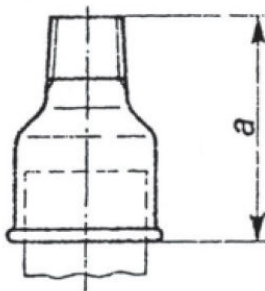

Ø	Dimensioni / Dimensions mm
	a
1/2 x 3/8	43
3/4 x 3/8	47
3/4 x 1/2	48
1 x 1/2	55
1 x 3/4	57
1.1/4 x 1/2	59
1.1/4 x 3/4	60
1.1/4 x 1	62
1.1/2 x 3/4	63
1.1/2 x 1	63
1.1/2 x 1.1/4	65
2 x 1	71
2 x 1.1/4	70
2 x 1.1/2	71
2.1/2 x 2	80

RA 280 Nipplo M-M
Nipple M-M
Mamelon M-M

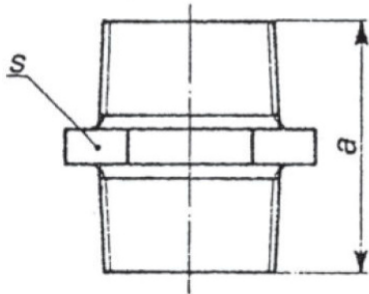

Ø	Dimensioni / Dimensions mm	Chiave / Key mm
	a	S
1/8	30	15
1/4	36	18
3/8	38	22
1/2	44	27
3/4	47	32
1	53	38
1.1/4	57	45
1.1/2	60	54
2	68	70
2.1/2	75	80
3	83	96
4	95	121
5	100	145
6	119	171

RA 290 Tappo con bordo M
Plug M
Bouchon M

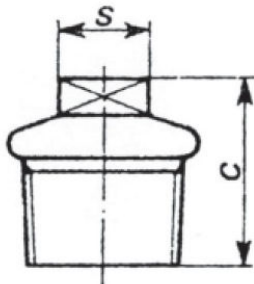

Ø	Dimensioni / Dimensions mm	Chiave / Key mm
	c min.	S
1/4	22	10
3/8	24	14
1/2	26	18
3/4	32	20
1	36	23
1.1/4	39	23
1.1/2	41	28
2	48	33
2.1/2	54	32
3	60	42
4	70	41

RA 300 Tappo F
Stop end F
Bouchon F

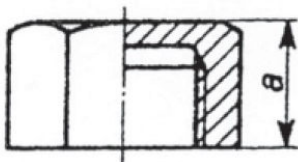

Ø	Dimensioni / Dimensions mm
	a min.
3/8	17
1/2	19
3/4	22
1	24
1.1/4	27
1.1/2	27
2	32
2.1/2	35
3	38
4	45

RA 340 Bocchettone diritto F-F
Straight union F-F
Union droit F-F

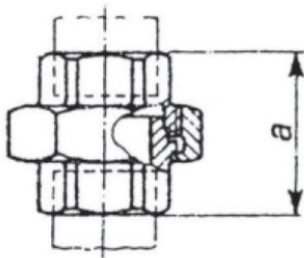

Ø	Dimensioni / Dimensions mm
	<i>a</i>
1/4	42
3/8	45
1/2	48
3/4	52
1	58
1.1/4	65
1.1/2	70
2	78
2.1/2	85
3	95
4	110

RA 341 Bocchettone diritto M-F
Straight union M-F
Union droit M-F

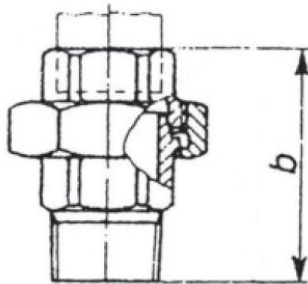

Ø	Dimensioni / Dimensions mm
	<i>b</i>
1/4	55
3/8	58
1/2	66
3/4	72
1	80
1.1/4	90
1.1/2	95
2	106
2.1/2	118
3	130
4	145

RA 180 Croce F-F-F-F
Cross fitting F-F-F-F
Raccord croisé F-F-F-F

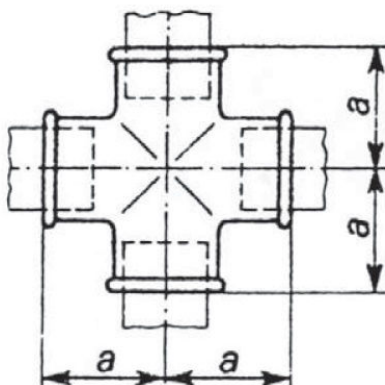

Ø	Dimensioni / Dimensions mm
	<i>a</i>
3/8	25
1/2	28
3/4	33
1	38
1.1/4	45
1.1/2	50
2	58
(2.1/2)	69
(3)	78
(4)	96