

**Scheda Tecnica / Technical Details / Fiche Technique**

**Cod. Art. FC 642**

**IT ::** Filtro gas omologato CE

**EN ::** CE approved gas filter

**FR ::** Filtre gaz homologué CE



largh. mm	Ø	codice
120	1/2"	FC0642000005
120	3/4"	FC0642000007
120	1"	FC0642000010
160	1"1/4	FC0642000012
160	1"1/2	FC0642000015
160	2"	FC0642000020

largh. mm	DN	codice
290	65	FC0642000065
310	80	FC0642000080
350	100	FC0642000100



**DESCRIZIONE**

E' un dispositivo che impedisce il passaggio di particelle di polvere o detriti portati dal gas proteggendo i dispositivi di regolazione e sicurezza.

E' composto da una cartuccia filtrante ampiamente dimensionata e realizzata in materiale sintetico lavabile; è completamente estraibile per una totale ispezione e pulizia.

Ciò è notevolmente facilitato dalle tenute appositamente realizzate con anelli di tipo O-Ring resistenti anche ai gas della terza famiglia.

Ogni filtro MADAS consente la misurazione della pressione a monte tramite un apposito attacco a norma.

**Norma di riferimento EN 126**

**In conformità a:**

**Direttiva PED 2014/68/UE**  
(ex 97/23/CE)

**Direttiva Gas 2009/142/CE**  
fino al 20/04/2018

**Regolamento (UE) 2016/426** dal  
21/04/2018



**DESCRIPTION**

It is a device that prevents the passage of a particles of dust or debris brought by the gas, protecting the regulation and safety device.

FM gas filters have a large filtering component made of synthetical washable material which is fully removable for complete inspection and cleaning.

Special O-Ring sealings, resistant to third gas family, make easy removal.

MADAS filters permits upstream pressure measurement through an appropriate standard connection.

**Reference standard EN 126**

**In conformity with:**

**2014/68/EU PED Directive**  
(ex 97/23/EC)

**2009/142/EC Gas Directive** until  
20/04/2018

**Regulation (EU) 2016/426**  
from 21/04/2018



**DESCRIPTION**

Les filtres pour gaz éliminent les particules de poussière portées par le gaz et protègent les éléments en danger (brûleurs, compteurs et régulateurs) d'une obstruction rapide.

Filtre pour gaz est composé d'une cartouche filtrante réalisée en matériau synthétique lavable; il est complètement extractible pour l'inspection complète et le nettoyage.

Cela est facilité par les joints d'étanchéité tout spécialement réalisés avec des bagues de type joints toriques qui résistent aussi aux gaz de la troisième famille.

Chaque filtre MADAS permet le mesurage de la pression en haut grâce à une fixation spécifique.

**Norme de référence EN 126**

**Conforme à:**

**Direttiva PED 2014/68/UE**  
(ex 97/23/CE)

**Direttiva Gaz 2009/142/CE** jusqu'au  
20/04/2018

**Règlement (UE) 2016/426**  
du 21/04/2018



## CARATTERISTICHE TECNICHE

- Impiego:  
gas non aggressivi delle 3 famiglie  
(gas secchi)  
Su richiesta versioni idonee per biogas
- Attacchi filettati Rp:  
(DN 15 ÷ DN 50) secondo EN 10226
- Attacchi flangiati PN 16:  
(DN 25 ÷ DN 300) secondo ISO 7005
- Su richiesta attacchi flangiati ANSI 150
- Pressione max esercizio:  
2 bar o 6 bar (vedere etichetta prodotto)
- Temperatura ambiente: -40 ÷ +70 °C
- Gruppo:  
2
- Filtraggio:  
50 µm - 20 µm - 10 µm
- Fattore di sicurezza: f=4 (5\*4 = 20 bar)  
secondo EN 13611:2015 punto F.7.9

## MATERIALI

- Alluminio pressofuso (UNI EN 1706)
- ottone OT-58 (UNI EN 12164)
- alluminio 11S (UNI 9002-5)
- acciaio zincato e acciaio INOX 430 F  
(UNI EN 10088)
- gomma antiolio NBR (UNI 7702)
- nylon 30% fibra di vetro  
(UNI EN ISO 11667)
- viledon

## MODELLI

A = Senza prese di pressione o tappi  
 B = 1 Presa di pressione G 1/8" in entrata  
 D = Presa di pressione G 1/8" in entrata e uscita  
 F = 1 Tappo G 1/8" in entrata  
 H = Tappo G 1/8" in entrata e uscita  
 I = 4 Tappi G 1/4"  
 L = 2 Prese di Pressione + 2 Tappi G 1/8"  
 M = Presa di pressione G 1/4" in entrata e uscita  
 N = 4 Prese di pressione G 1/4"  
 O = 2 Prese di Pressione + 2 Tappi G 1/4"  
 J = Tappo G 1/4" in entrata e uscita



## TECHNICAL DATA

- Use:  
not aggressive gases of the 3 families  
(dry gases)  
On request biogas versions available too
- Threaded connections Rp:  
(DN 15 ÷ DN 50) according to EN 10226
- Flanged connections PN 16:  
(DN 25 ÷ DN 300) according to ISO 7005
- On request ANSI 150 flanged connections
- Max. working pressure:  
2 bar or 6 bar (see product label)
- Environment temperature: -40 ÷ +70 °C
- Group:  
2
- Filtration:  
50 µm - 20 µm - 10 µm
- Safety factor: f=4 (5\*4 = 20 bar)  
according to EN 13611:2015 point F.7.9

## MATERIALS

- Die-cast aluminium (UNI EN 1706)
- OT-58 brass (UNI EN 12164)
- 11S aluminium (UNI 9002-5)
- galvanized and 430 F stainless steel  
(UNI EN 10088)
- NBR rubber (UNI 7702)
- nylon 30% glass fibre (UNI EN ISO 11667)
- viledon

## MODELS

A = Without pressure nipples or caps  
 B = Inlet G 1/8" pressure nipple  
 D = Inlet and outlet G 1/8" pressure nipple  
 F = Inlet G 1/8" cap  
 H = Inlet and outlet G 1/8" cap  
 I = 4 G 1/4" caps  
 L = 2 G 1/8" pressure nipples and 2 G 1/8" caps  
 M = Inlet and outlet G 1/4" pressure nipple  
 N = 4 G 1/4" pressure nipples  
 O = 2 G 1/4" pressure nipples and 2 G 1/4" caps  
 J = Inlet and outlet G 1/4" cap



## CARACTERISTIQUES TECHNIQUES

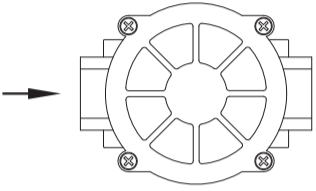
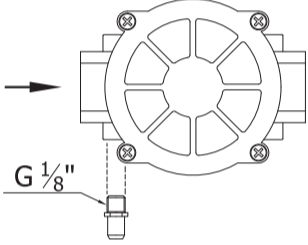
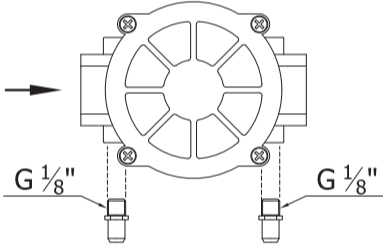
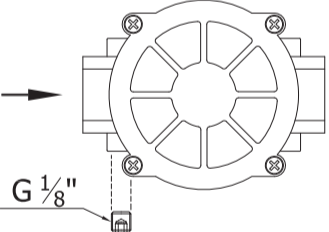
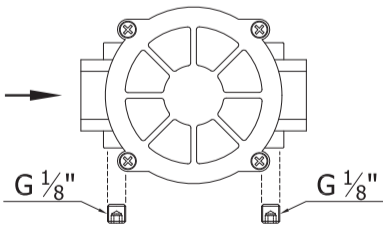
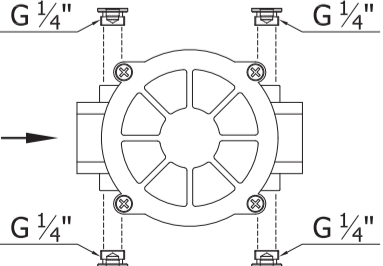
- Emploi:  
gaz non agressifs des trois familles  
(gaz secs)  
Sur les versions biogas, construction  
uniquement en aluminium – Pas de pièce  
en laiton
- Fixations filetees Rp:  
(DN 15 ÷ DN 50) selon EN 10226
- Fixations bridees PN 16:  
(DN 25 ÷ DN 300) selon ISO 7005
- Sur demande fixations bridees ANSI 150
- Pression maximale en exercice:  
2 bar ou 6 bar (voir étiquette du produit)
- Température ambiante: -40 ÷ +70 °C
- Groupe: 2
- Filtrage:  
50 µm - 20 µm - 10 µm
- Facteur de sécurité: f=4 (5\*4 = 20 bar)  
selon EN 13611:2015 point F.7.9

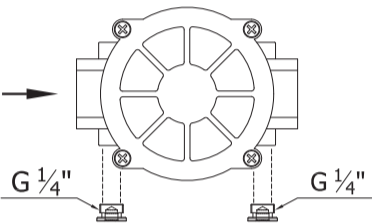
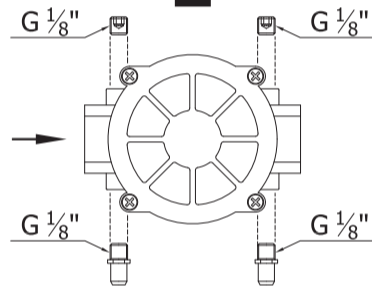
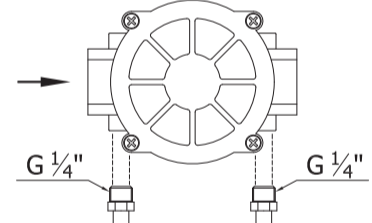
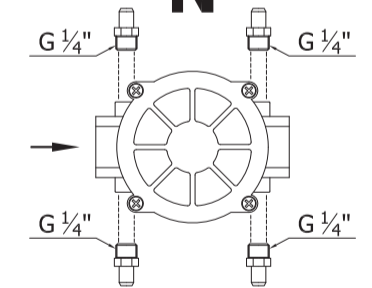
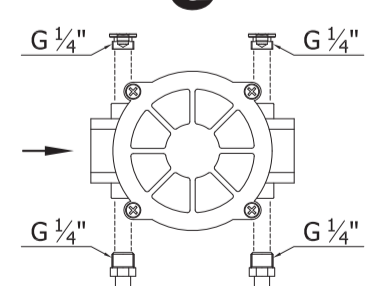
## MATÉRIELS

- Alluminium fondé dans la masse (UNI EN 1706)
- laiton OT-58 (UNI EN 12164)
- aluminium 11S (UNI 9002-5)
- acier zingué et acier INOX 430 F  
(UNI EN 10088)
- caoutchou anti-huile NBR (UNI 7702)
- nylon 30% fibre de verre  
(UNI EN ISO 11667)
- viledon

## MODELES

A = Sans prises de pression ou bouchons  
 B = Prise de pression G 1/8" en 'entrée  
 D = Prise de pression G 1/8" en entrée/sortie  
 F = 1 Bouchon G 1/8" en entrée  
 H = Bouchon G 1/8" en entrée/sortie  
 I = 4 Bouchons G 1/4"  
 L = 2 Prises de Pression + 2 Bouchons G 1/8"  
 M = Prise de pression G 1/4" en entrée/sortie  
 N = 4 Prises de pression G 1/4"  
 O = 2 Prises de pression + 2 Bouchons G 1/4"  
 J = Bouchon G 1/4" en entrée/sortie

Modello Model Modèle	Attacchi - Connections - Fixations		
	DN 15 - DN 20 - DN 25	DN 25M - DN 32 DN 40 - DN 50	DN 65 - DN 80 - DN 100 DN 125 - DN 150
<p><b>A</b></p> 	✔	✔	✔
<p><b>B</b></p> 	✔	✔	✔
<p><b>D</b></p> 	✔	✔	✔
<p><b>F</b></p> 	✔	✔	✔
<p><b>H</b></p> 	✔	✔	✔
<p><b>I</b></p> 	✘	✔	✔

Modello Model Modèle	Attacchi - Connections - Fixations		
	FM DN 15 - DN 20 - DN 25	FM DN 25M - DN 32 DN 40 - DN 50	FM DN 65 - DN 80 - DN 100 DN 125 - DN 150
<p><b>J</b></p> 	✘	✔	✔
<p><b>L</b></p> 	✔	✔	✔
<p><b>M</b></p> 	✘	✔	✔
<p><b>N</b></p> 	✘	✔	✔
<p><b>O</b></p> 	✘	✔	✔

### FMC DN 15 ÷ 25

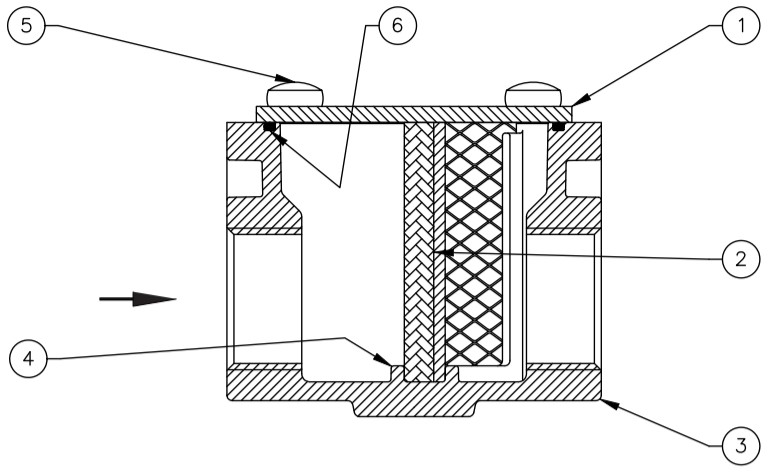
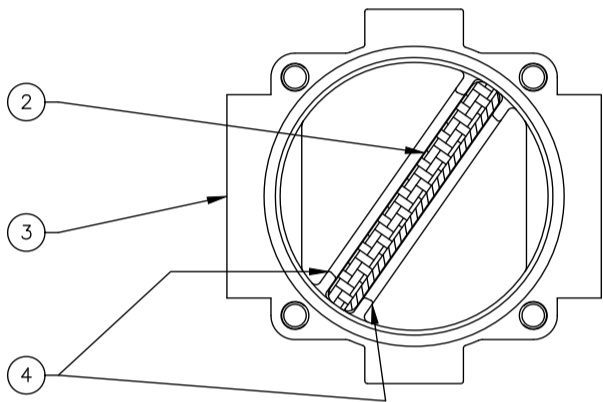


fig. 1



vista dall'alto senza coperchio  
view from above without cover  
vue du haut sans couvercle



fig. 1, 2, 3 e 4

- 1 - Coperchio / Fondello
- 2 - Organo filtrante
- 3 - Corpo
- 4 - Guide di sistemazione
- 5 - Viti di fissaggio
- 6 - O-Ring di tenuta
- 7 - Presa di pressione



fig. 1, 2, 3 and 4

- 1 - Cover / Bottom
- 2 - Filtering organ
- 3 - Body
- 4 - Slotting guides
- 5 - Fixing screws
- 6 - Seal O-Ring
- 7 - Pressure nipple



fig. 1, 2, 3 et 4

- 1 - Couvercle / Basement
- 2 - Composant filtrant
- 3 - Corps
- 4 - Guides
- 5 - Vis de fixation
- 6 - O-Ring de tenue
- 7 - Prise de pression

### FM DN 15 ÷ 25

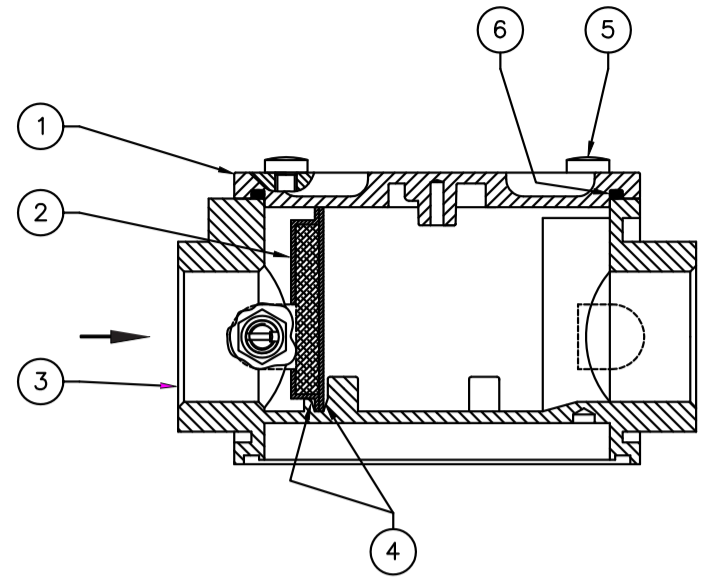
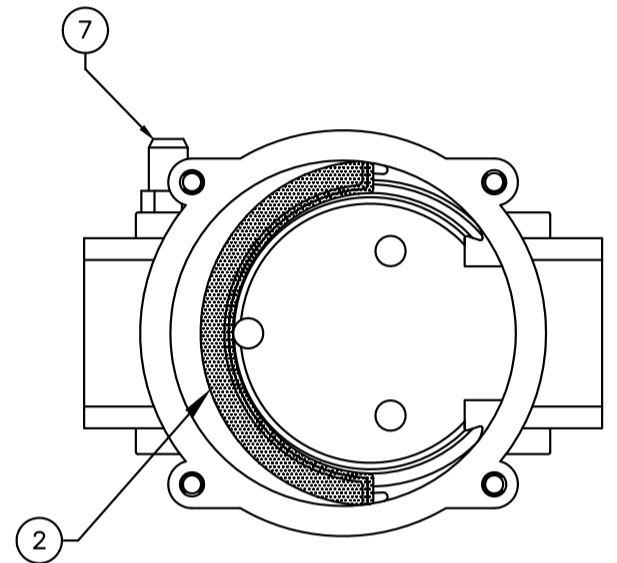


fig. 2



vista dall'alto senza coperchio  
view from above without cover  
vue du haut sans couvercle

### FM DN 32 ÷ 50

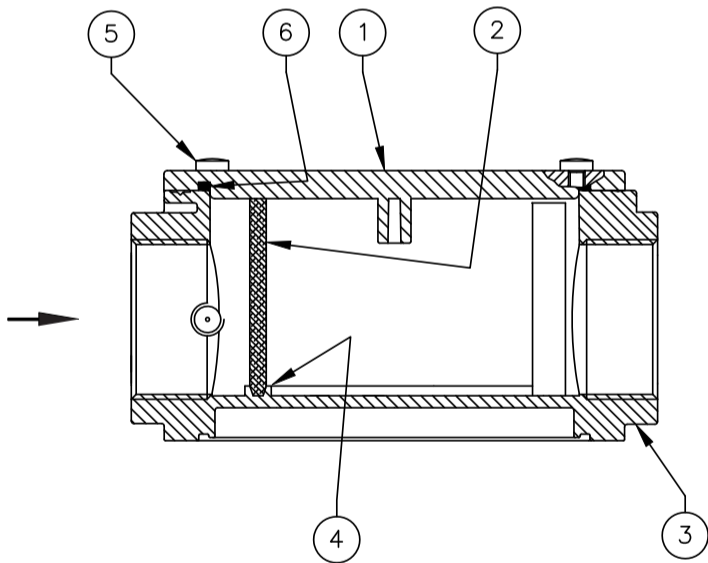
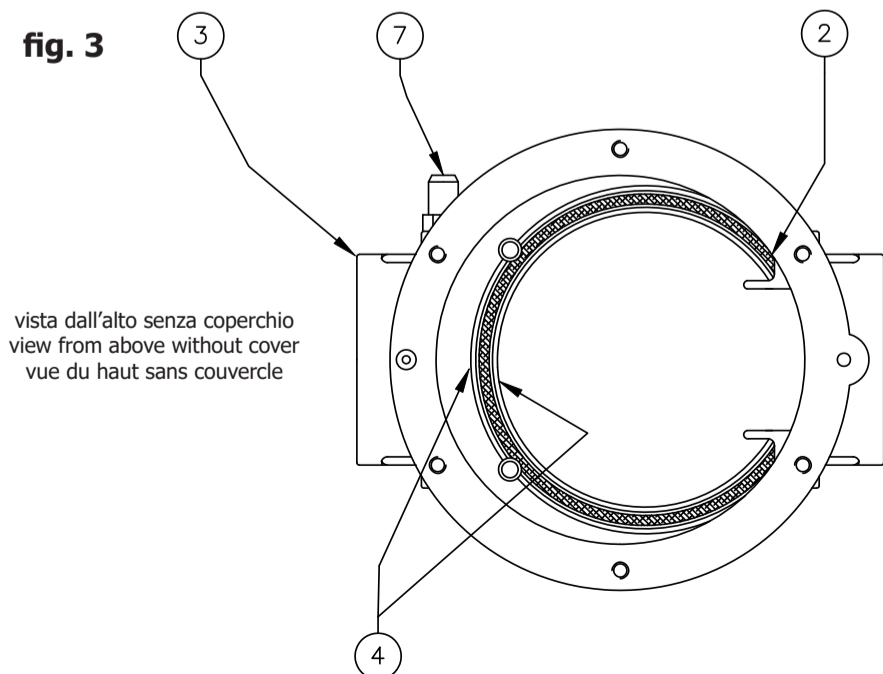


fig. 3



vista dall'alto senza coperchio  
view from above without cover  
vue du haut sans couvercle

### FGM DN 25 ÷ 50

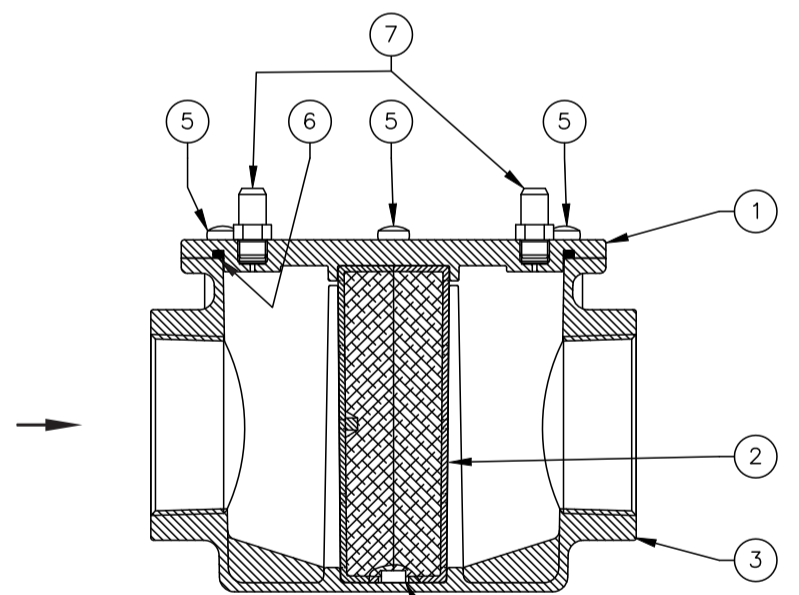
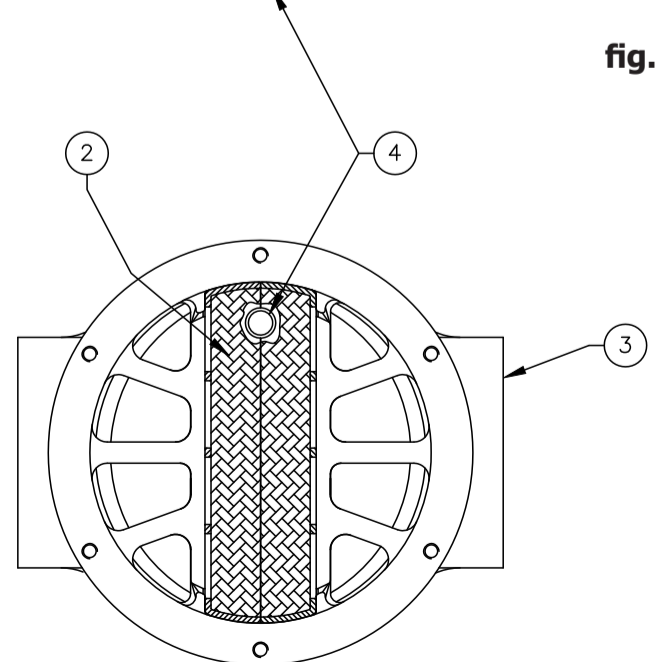
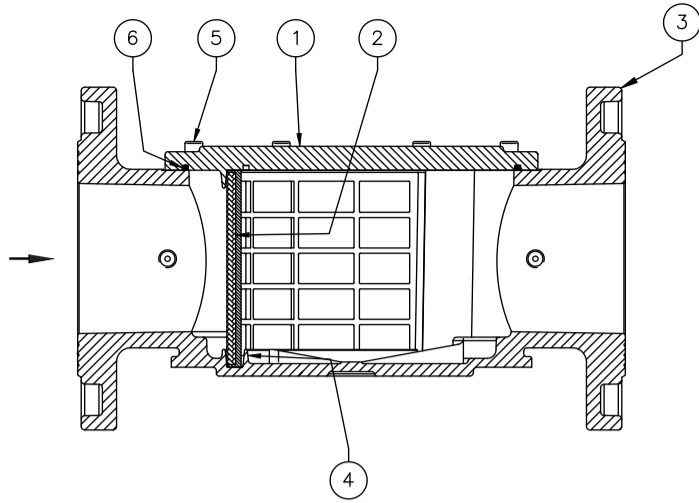


fig. 4

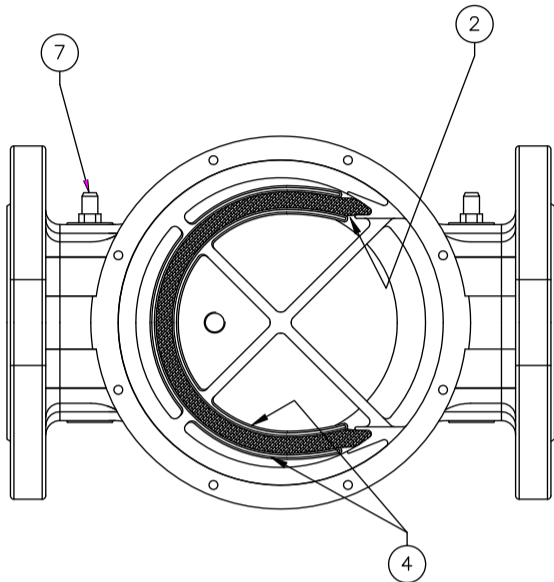


vista dall'alto senza coperchio  
view from above without cover  
vue du haut sans couvercle

**FM DN 65 - 80**

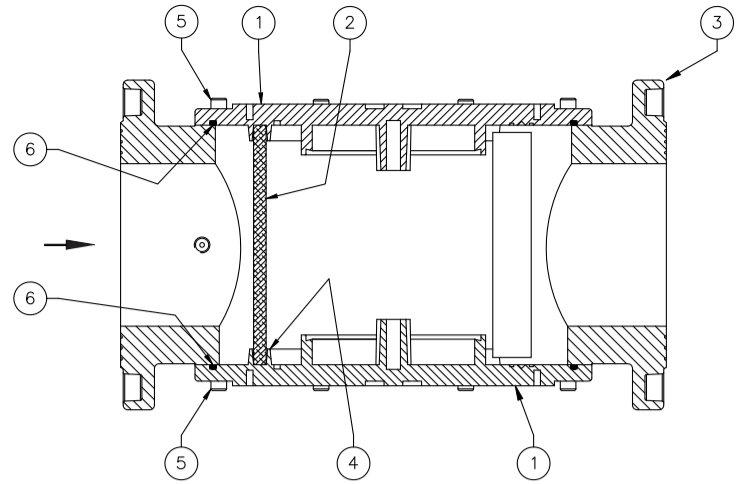


**fig. 5**

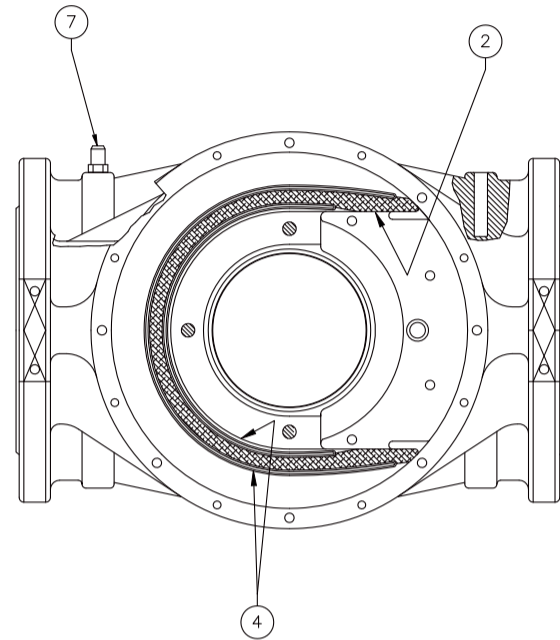


vista dall'alto senza coperchio  
view from above without cover  
vue du haut sans couvercle

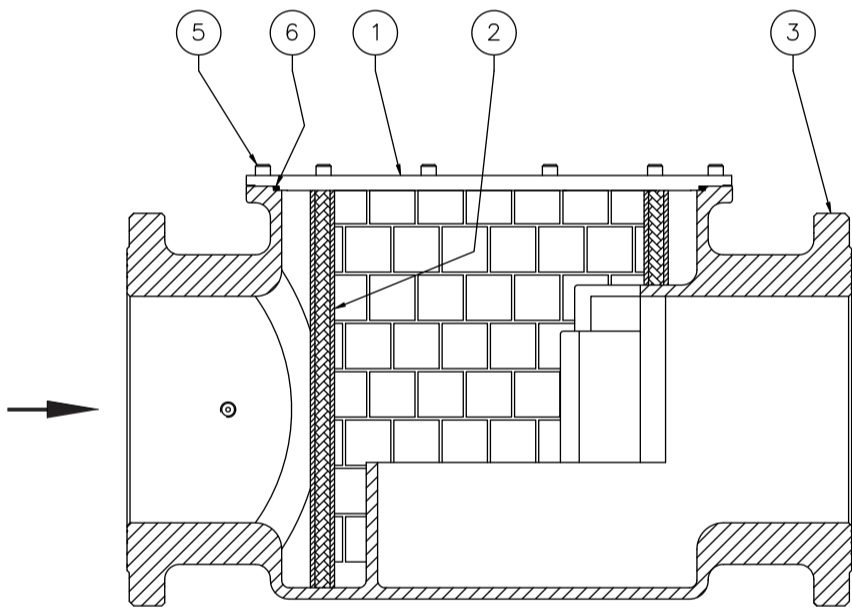
**FM DN 100**



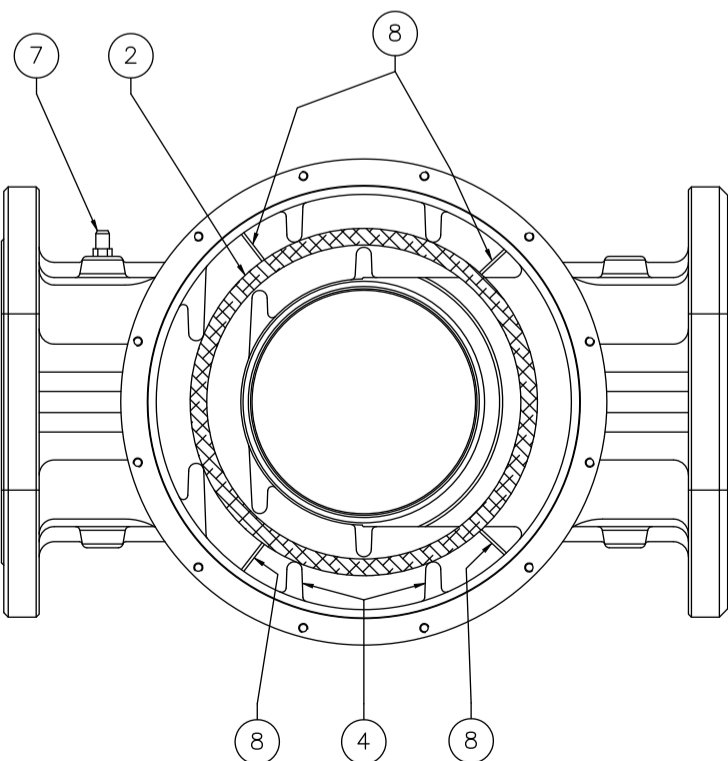
**fig. 6**



**FM DN 125 ÷ 300**



**fig. 7**



vista dall'alto senza coperchio  
view from above without cover  
vue du haut sans couvercle



**fig. 5,6 e 7**

- 1 - Coperchio / Fondello
- 2 - Organo filtrante
- 3 - Corpo
- 4 - Guide di sistemazione
- 5 - Viti di fissaggio
- 6 - O-Ring di tenuta
- 7 - Presa di pressione
- 8 - Alette speciali



**fig. 5, 6 and 7**

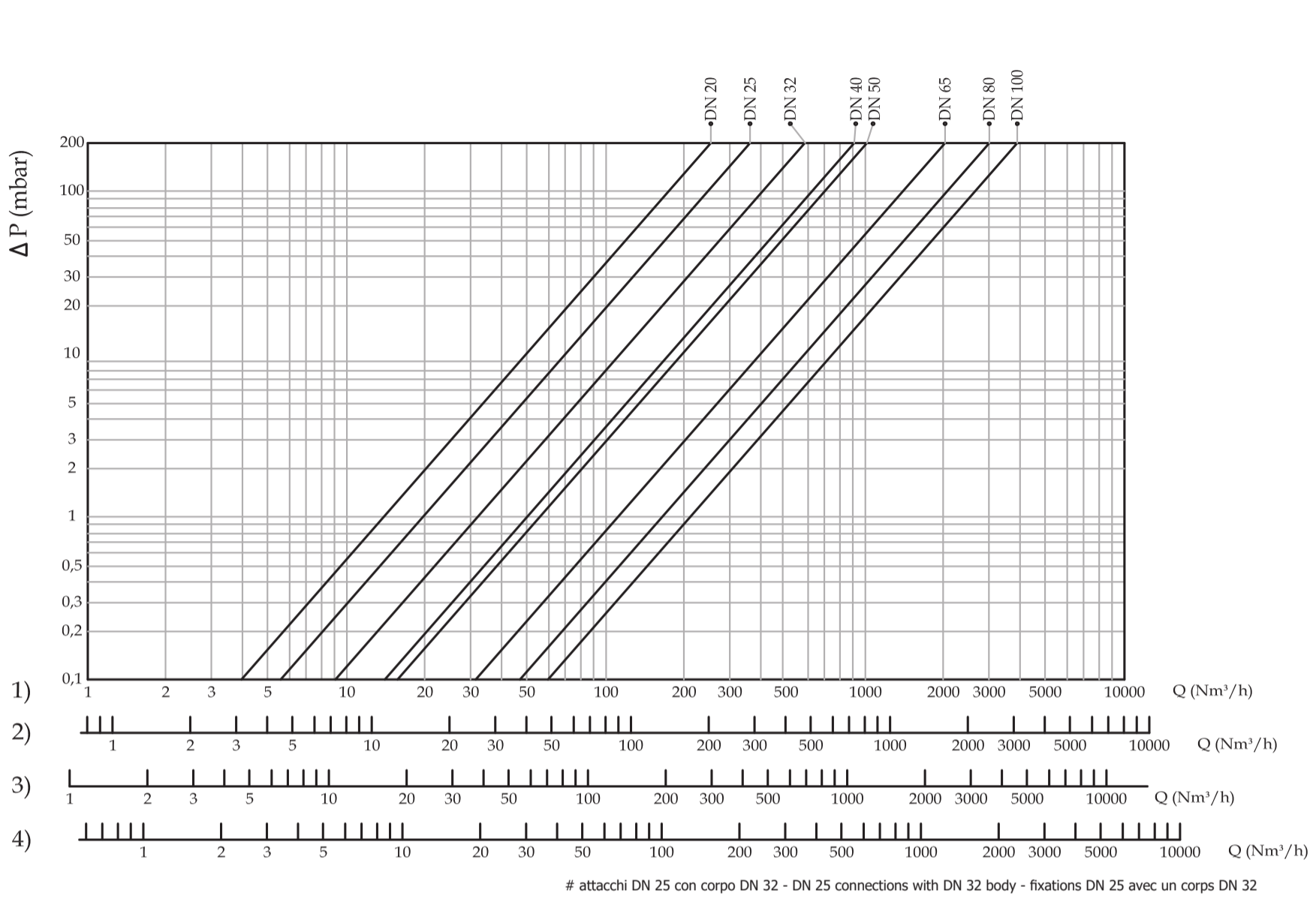
- 1 - Cover / Bottom
- 2 - Filtering organ
- 3 - Body
- 4 - Slotting guides
- 5 - Fixing screws
- 6 - Seal O-Ring
- 7 - Pressure nipple
- 8 - Special tongues



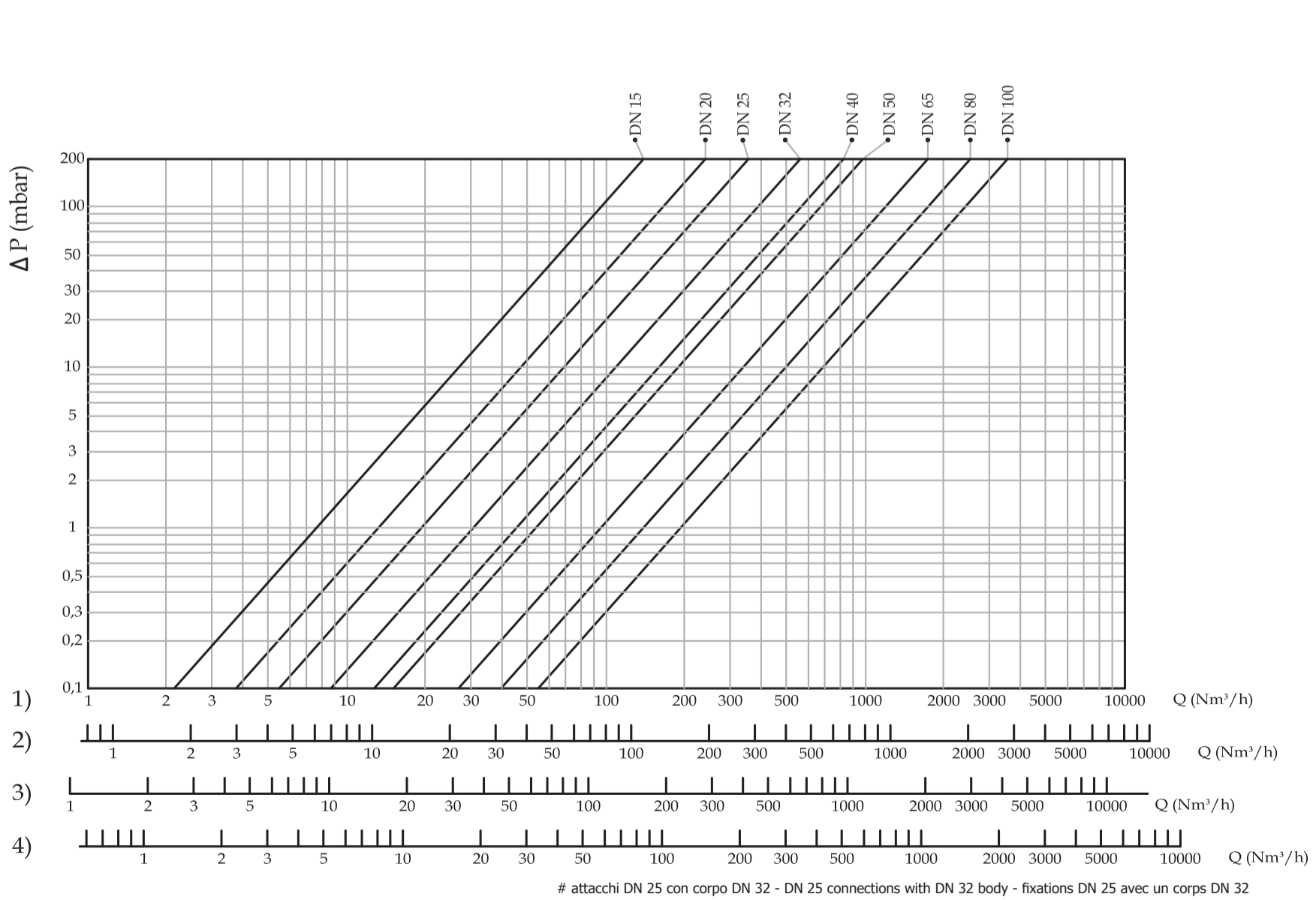
**fig. 5,6 et 7**

- 1 - Couvercle / Basement
- 2 - Composant filtrant
- 3 - Corps
- 4 - Guides
- 5 - Vis de fixation
- 6 - O-Ring de tenue
- 7 - Prise de pression
- 8 - Ailettes spéciales

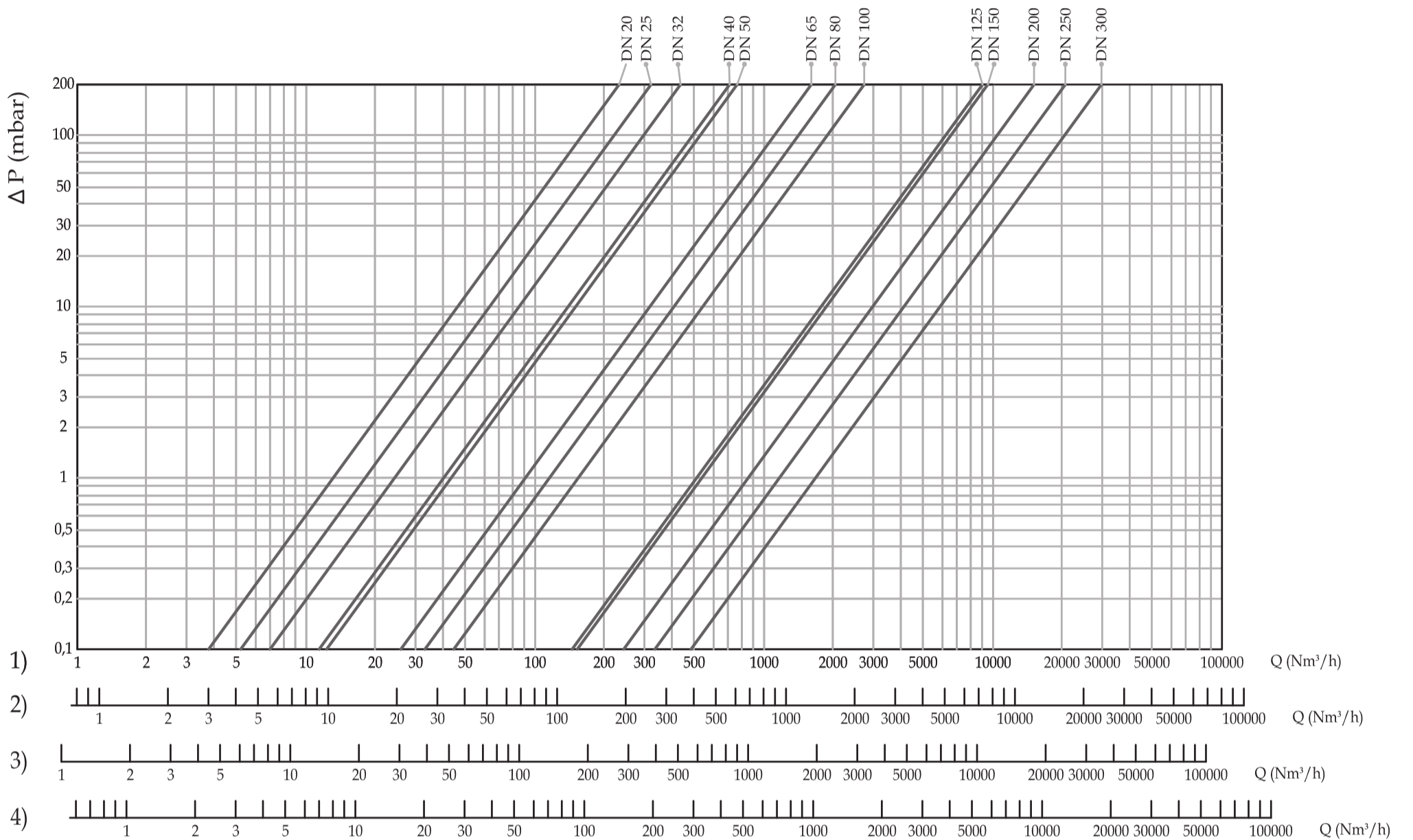
**DIAGRAMMA PERDITE DI CARICO (filtraggio 50 μ)**  
**PRESSURE DROP DIAGRAM (50 μ filtering)**  
**DIAGRAMME PERTES DE CHARGE (filtrage 50 μ)**



**DIAGRAMMA PERDITE DI CARICO (filtraggio 20 μ)**  
**PRESSURE DROP DIAGRAM (20 μ filtering)**  
**DIAGRAMME PERTES DE CHARGE (filtrage 20 μ)**



**DIAGRAMMA PERDITE DI CARICO (filtraggio 10 μ)**  
**PRESSURE DROP DIAGRAM (10 μ filtering)**  
**DIAGRAMME PERTES DE CHARGE (filtrage 10 μ)**



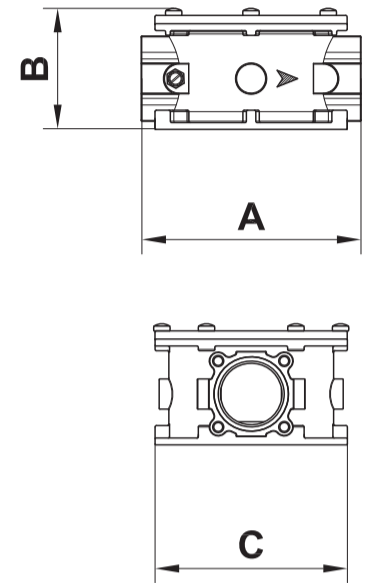
 1) metano  
 2) aria  
 3) gas di città  
 4) gpl

 1) methane  
 2) air  
 3) town gas  
 4) lpg

 1) méthane  
 2) air  
 3) gaz de ville  
 4) gaz liquide

# attacchi DN 25 con corpo DN 32 - DN 25 connections with DN 32 body - fixations DN 25 avec un corps DN 32

Attacchi filettati Threaded connections Fixations filetees	Attacchi flangiati Flanged connections Fixations bridees	A	B	C min	superficie filtrante (mm <sup>2</sup> ) filtering surface (mm <sup>2</sup> ) filtre de surface (mm <sup>2</sup> )
DN 15 - DN 20 - DN 25 P. max 2 bar	-	120	72	94	4560
DN 15 - DN 20 - DN 25 P. max 6 bar	-	120	76	94	4560
-	DN 25	192	115	115	4560
DN 25M	-	160	87	140	19040
-	DN 25M	230	115	140	19040
DN 32 - DN 40	-	160	87	140	19040
DN 50	-	160	110	140	26770
-	DN 65	290	180	198	39240
-	DN 80	310	195	198	39240
-	DN 100	350	211	254	76250
-	DN 125 - DN 150 P. max 2 bar	480	310	328	163550
-	DN 125 - DN 150 P. max 6 bar	480	315	328	163550
-	DN 200	600	380	450	201000
-	DN 250	673	455	510	280000
-	DN 300	737	510	540	334000



DN 25M = attacchi DN 25 con corpo DN 32 = DN 25 connections with DN 32 body = fixations DN 25 avec corps DN 32



## INSTALLAZIONE



Si raccomanda di leggere attentamente il foglio di istruzioni a corredo di ogni prodotto.

**ATTENZIONE:** le operazioni di installazione/manutenzione devono essere eseguite da personale qualificato.

- E' necessario chiudere il gas prima dell'installazione.
- Verificare che la pressione di linea **NON SIA SUPERIORE** alla pressione massima dichiarata sull'etichetta del prodotto.
- Il filtro è normalmente posizionato a monte di tutti gli organi di regolazione e intercettazione. Deve essere installato con la freccia (in rilievo sul corpo in alluminio o sul coperchio) rivolta verso l'utenza.
- Può essere installato in qualsiasi posizione senza che ne venga pregiudicato il corretto funzionamento. All'esterno del filtro è sistemata una presa di pressione per l'eventuale controllo.
- Durante l'installazione evitare che detriti o residui metallici penetrino all'interno dell'apparecchio.
- Se l'apparecchio è filettato verificare che la lunghezza del filetto della tubazione non sia eccessiva per non danneggiare il corpo dell'apparecchio in fase di avvitamento.
- Se l'apparecchio è flangiato verificare che le controflange di ingresso e uscita siano perfettamente parallele per evitare di sottoporre il corpo a inutili sforzi meccanici, calcolare inoltre lo spazio per l'inserimento della guarnizione di tenuta. Se a guarnizioni inserite lo spazio rimanente è eccessivo non cercare di colmarlo stringendo eccessivamente i bulloni dell'apparecchio.
- In ogni caso dopo l'installazione verificare la tenuta dell'impianto.

## ESEMPIO DI INSTALLAZIONE

1. Valvola a strappo
2. Filtro gas serie FC 642
3. Valvola di blocco MAX o MIN
4. Regolatore gas
5. Valvola di sfioro
6. Leva comando a distanza valvola a strappo



## INSTALLATION



It is always important to read carefully the instruction sheet of each product.

**WARNING:** all installation/ maintenance work must be carried out by skilled staff.

- The gas supply must be shut off before installation.
- Check that the line pressure **DOES NOT EXCEED** the maximum pressure stated on the product label.
- The filter is normally installed upstream the regulation organs and the interception device. It must be installed with the arrow (on the body valve) towards the user.
- It can be installed in any position without compromising the correct working. Outside the filter there is a checking pressure-tap.
- During installation take care not to allow debris or scraps of metal to enter the device.
- If the device is threaded check that the pipeline thread is not too long; overlong threads may damage the body of the device when screwed into place.
- If the device is flanged check that the inlet and outlet counterflanges are perfectly parallel to avoid unnecessary mechanical stresses on the body of the device. Also calculate the space needed to fit the seal. If the gap left after the seal is fitted is too wide, do not try to close it by over-tightening the device's bolts.
- Always check that the system is gas-tight after installation.

## EXAMPLE OF INSTALLATION

1. Jerk handle ON/OFF valve
2. FC 642 series gas filter
3. MAX or MIN shut off valve
4. Pressure regulator
5. Overflow valve
6. Lever for remote ON/OFF valve control



## INSTALLATION



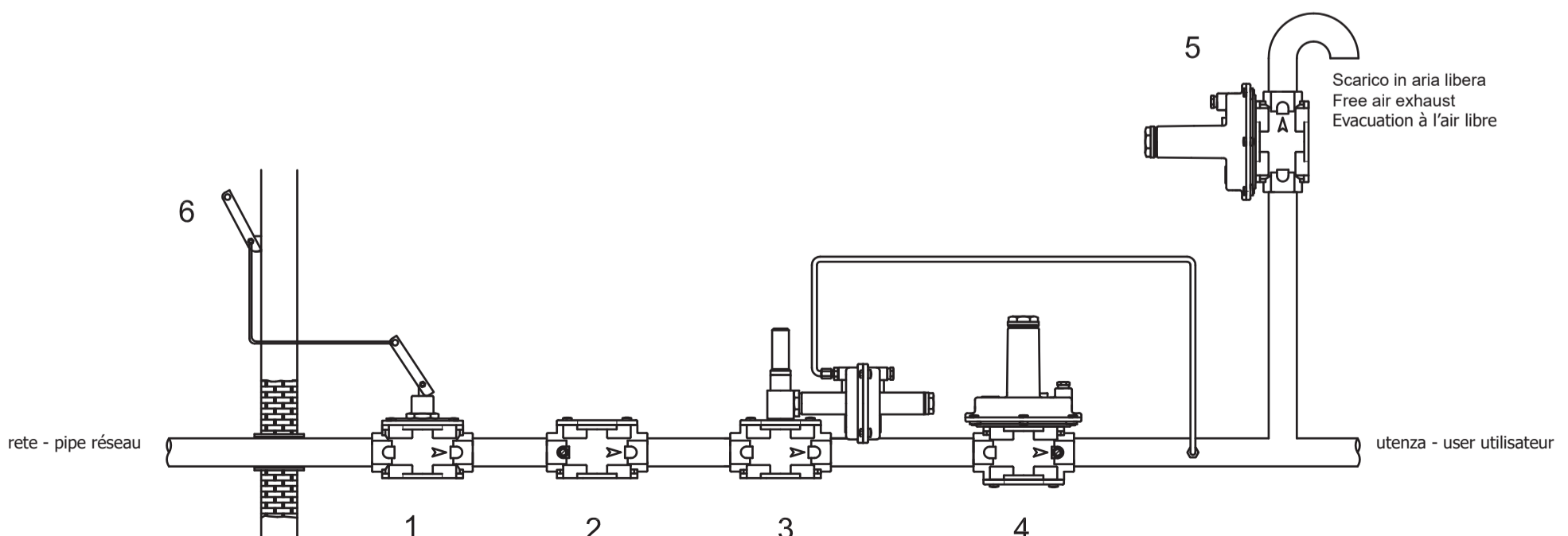
Lire attentivement les instructions pour chaque produit.

**ATTENTION:** les opérations d'installation/entretien doivent être exécutées par du personnel qualifié.

- Fermer le gaz avant l'installation.
- Vérifier que la pression de ligne **NE SOIT PAS SUPÉRIEURE** à la pression maximum déclarée sur l'étiquette du produit.
- Le filtre est normalement situé en amont de tous les organes de réglage et d'arrêt. Il doit être installé avec la flèche (en relief sur le corps ou sur le couvercle) tournée vers le tuyau principal.
- Il peut être installé dans n'importe quelle position sans que son fonctionnement correct soit compromis. A l'extérieur du filtre est installée une prise de pression pour l'éventuel contrôle.
- Pendant l'installation, éviter que des débris ou des résidus métalliques pénètrent dans l'appareil.
- Si l'appareil est fileté, vérifier que le filet de la tuyauterie ne soit pas trop long pour ne pas endommager le corps de l'appareil lors du vissage.
- Si l'appareil est bridé, vérifier que les contrebrides d'entrée et de sortie soient parfaitement parallèles pour éviter de soumettre le corps à des efforts mécaniques inutiles; par ailleurs, calculer l'espace pour l'introduction du joint d'étanchéité. Si, lorsque les joints sont introduits, l'espace restant est excessif, ne pas essayer de le combler en serrant trop fort les boulons de l'appareil.
- De toute façon, après l'installation vérifier l'étanchéité de l'installation.

## EXEMPLE D'INSTALLATION

1. Soupape à déchirement
2. Filtre gaz
3. Soupape de bloc MAX ou MIN
4. Régulateur gaz
5. Soupape d'effleurment
6. Levier de comande à distance soupape à déchirement





## MANUTENZIONE

In ogni caso prima di effettuare verifiche interne accertarsi che all'interno dell'apparecchio non vi sia gas in pressione.

Togliere il coperchio (1) svitando le viti di fissaggio (5). Smontare la cartuccia filtrante (2), pulirla con acqua e sapone, soffiarla con aria compressa (o sostituirla se necessario) e rimontarla nella posizione iniziale controllando che sia sistemata tra le apposite guide (4) controllando che non ostacoli il montaggio del coperchio (1).

Infine rimontare il coperchio (1) facendo attenzione che l'O-Ring (6) sia sistemato nell'apposita cava.



**Le suddette operazioni devono essere eseguite esclusivamente da tecnici qualificati.**



## SERVICING

In all cases, before performing any internal checks make sure that there is no pressurised gas inside the device.

Remove cover (1) and unscrew the fixing screws (5). Disassemble the filter cartridge (2), clean with soap and water, blow with compressed air (or substitute if necessary) and re-assemble in the original position checking that it is properly positioned in the guides (4), and check that it does not prevent assembly of the cover (1).

Lastly re-assemble the cover (1) making sure that the O-ring (6) is in the correct position.



**The above-said operations must be carried out only by qualified technicians.**



## MANUTENTION

Avant de faire des vérifications internes, s'assurer qu'il n'y ait pas de gaz sous pression dans l'appareil.

Enlever le couvercle (1) en dévissant les vis de fixation (5). Démontez la cartouche filtrante (2), la nettoyer avec de l'eau et du savon et y souffler de l'air comprimé (ou la remplacer si nécessaire); la remonter dans la position initiale en contrôlant qu'elle soit bien placée entre les guides (4) et qu'elle ne gêne pas le montage du couvercle (1).

Remonter le couvercle (1) en faisant attention que le joint torique (6) soit placé dans son logement.



**Les opérations mentionnées ci-dessus doivent être exécutées exclusivement par des techniciens qualifiés.**