

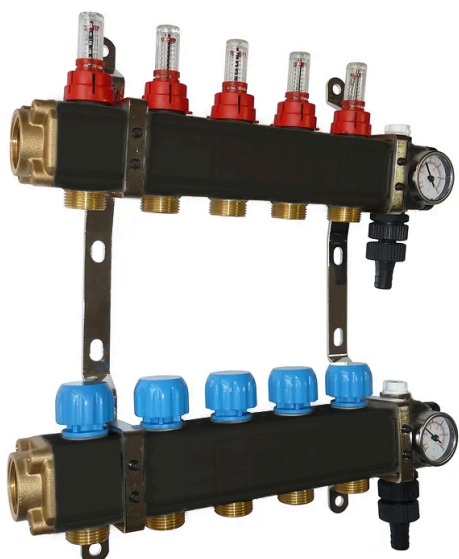

<b>IT</b> ::	Collettore in polimero doppia camera per riscaldamento radiante
<b>EN</b> ::	Double chamber polymer manifold for radiant heating
<b>FR</b> ::	Collecteur polymère à double chambre pour chauffage radiant

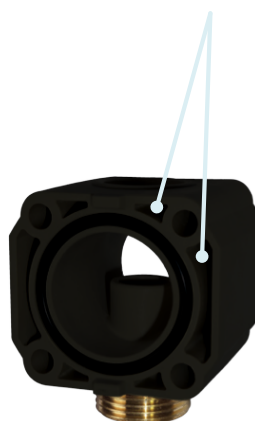

camera anti condensa /  
 anti-condensation chamber/  
 chambre anti-condensation



Collettore di distribuzione radiante da 3 a 12 vie  
 1"-3/4"

 **Caratteristiche**

- Collettore modulare in tecnopolimero;
- Valvole di intercettazione predisposte per comando elettrotermico;
- Misuratori di portata;
- Termometro integrato;
- Gruppo terminale con disareatore a rubinetto di scarico.

Distribution manifolds heating floor from 3 to 12 ways  
 1"-3/4"

 **features**

- Modular manifold in technopolymer;
- Shut-Off valves preset for electrothermal actuators;
- Flow meters;
- Built-in thermometer;
- Adjustable an piece with drain valve and manual air vent valve.

Collecteur de distribution placher chauffant - 3 jusqu'à 12 voies 1"-3/4"

 **fonctionnalités**

- Collecteur modulaire en technopolymère;
- Vannes d'arrêt prédisposées pour tête électrothermique ;
- Débitmètres;
- Thermomètre intégré;
- Group terminal d'évacuation air et robinet de vidange .

 <b>Dettagli Tecnici</b>	
<b>Corpo:</b>	Struttura modulare in tecnopolimero
<b>Connessioni principali:</b>	1" Eurokonus
<b>Derivazioni:</b>	3/4" Eurokonus
<b>Temperatura massima:</b>	70°C
<b>Pressione massima:</b>	6 bar
<b>% di glicole massima:</b>	50%
<b>Profondità min. cassetta:</b>	90 mm

 <b>Technical Details</b>	
<b>Body:</b>	Modular structure in technopolymer
<b>Main connections:</b>	1" Eurokonus
<b>Outlets connections:</b>	3/4" Eurokonus
<b>Maximum temperature:</b>	70°C
<b>Maximum pressure:</b>	6 bar
<b>% glycol maximum:</b>	50%
<b>Depth min. box:</b>	90 mm

 <b>Fiche Technique</b>	
<b>Corps:</b>	Structure modulaire en technopolymère
<b>Principales connexions:</b>	1" Eurokonus
<b>Connexions de sortie:</b>	3/4" Eurokonus
<b>Température maximale:</b>	70°C
<b>Pression maximale:</b>	6 bar
<b>% glycol maximum:</b>	50%
<b>Profondeur mini. cassette</b>	90 mm

### Dimensioni / Dimensions

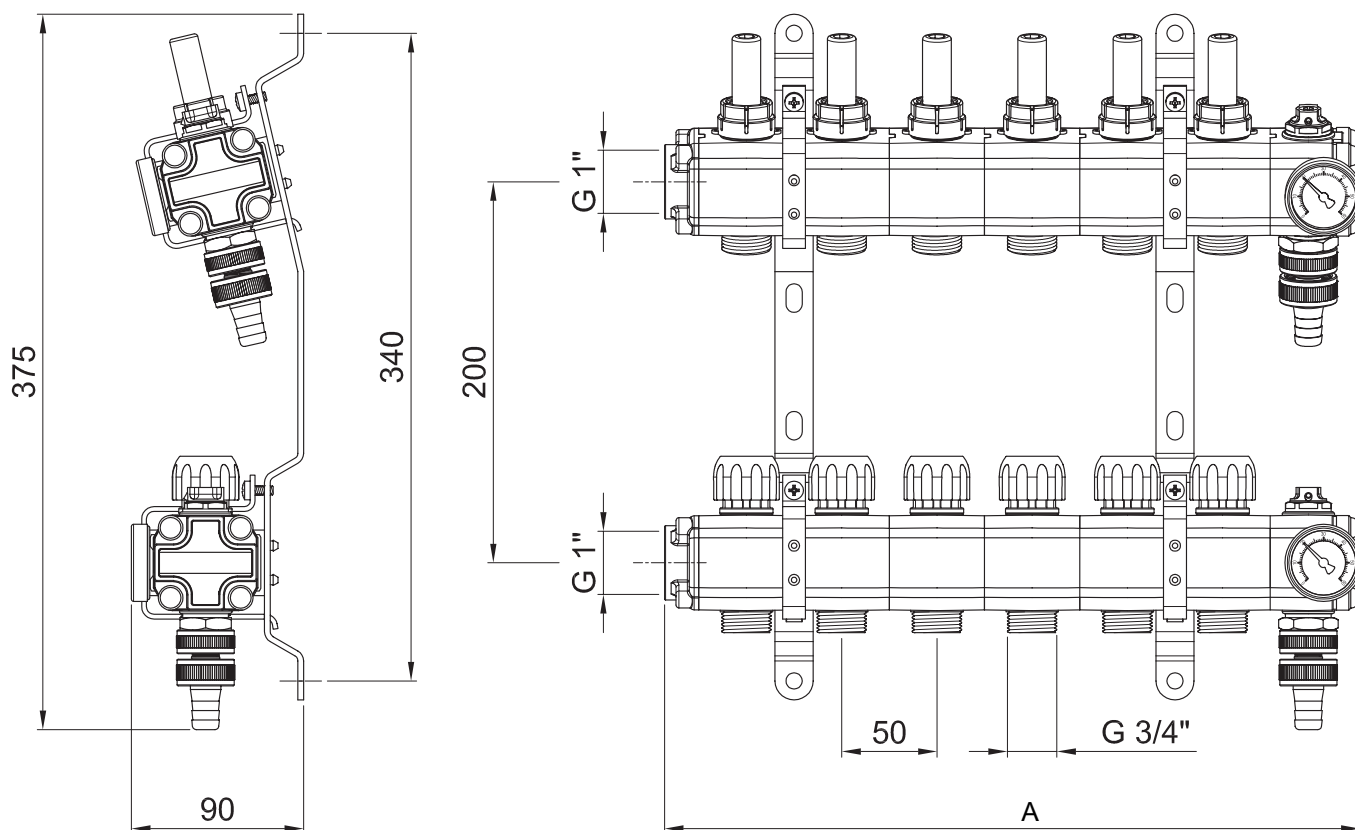

	3	4	5	6	7	8	9	10	11	12
<b>A</b>	215	265	315	365	415	465	515	565	615	665

## Regolazione del flussimetro / Flow meter regulating / réglage du débitmètre

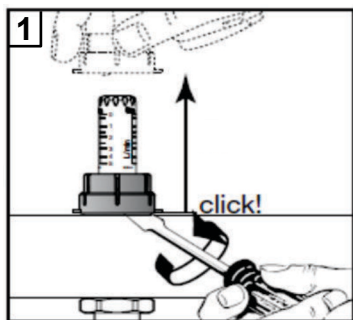

**IT** Rimuovere il fermo a ghiera rosso in plastica, applicando la necessaria forza con un cacciavite, utilizzandolo come nell'immagine;

**UK** Remove the red plastic ring retainer, applying the necessary force with a screwdriver, using it as in the image;

**FR** Retirer l'anneau de retenue en plastique rouge, en appliquant la force nécessaire avec un tournevis, en l'utilisant comme sur l'image;

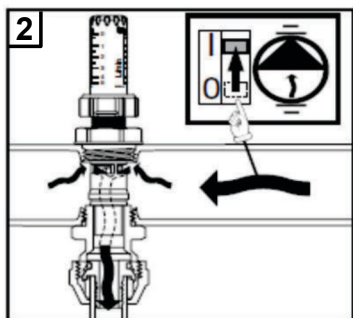

**IT** Assicurarsi che la pompa che si occupa di mandare l'acqua nel collettore sia accesa, in modo tale da poter verificare in tempo reale l'esito della regolazione;

**UK** Make sure that the pump that sends the water into the collector is turned on, so that you can check the outcome of the adjustment in real time;

**FR** Assurez-vous que la pompe qui envoie l'eau dans le collecteur soit allumée, afin de pouvoir vérifier le résultat du réglage en temps réel;

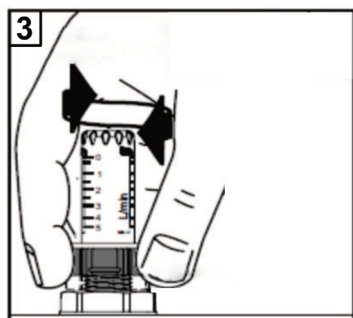

**IT** Ruotare l'anello di regolazione in plastica nera in senso orario per ridurre il flusso nel circuito da regolare, viceversa, ruotarlo in senso antiorario per aumentarlo. Verificare la scala graduata indicante i L/min sul flussimetro. Attraverso questa regolazione, un anello rosso si posiziona sulla capacità desiderata.

**UK** Rotate the black plastic adjustment ring clockwise to reduce the flow in the circuit has to be adjusted vice versa, rotate it counterclockwise to increase it. Check the graduated scale indicating L/min on the flow meter. Through this adjustment, a red ring is positioned on the desired capacity.

**FR** Tournez la bague de réglage en plastique noir dans le sens des aiguilles d'une montre pour réduire le débit dans le circuit à réguler, inversement, tournez-le dans le sens inverse des aiguilles d'une montre pour l'augmenter. Vérifiez l'échelle graduée indiquant L/min sur le débitmètre. Grâce à ce réglage, un anneau rouge se positionne sur la contenance souhaitée.